



# BEVERAGE-AIR

Project: \_\_\_\_\_

AIA#

Item: \_\_\_\_\_

Location: \_\_\_\_\_

SIS#

Approved: \_\_\_\_\_

## BB BACK BAR EQUIPMENT

BB48HC Sliding Glass Door Food Rated with Stainless Steel Top  
Hydrocarbon Series

### MODELS:

BB48HC-1-F-GS-B-27

BB48HC-1-F-GS-S-27

BB48HC Back Bar Refrigerators: Sliding Glass Door Series

**3 Year Parts/Labor Warranty**  
**Additional 2 Year Compressor Warranty**

### CABINET CONSTRUCTION

- Black or stainless steel exterior
- Interior construction utilizes galvanized steel on walls and ceiling, heavy duty stainless steel floor
- Full electronic control
- 2" Stainless steel top
- Two (2) epoxy coated shelves per section, standard
- Self-closing doors
- Stay-open feature & lock standard
- Black frame regardless of exterior finish
- LED lighting
- Certified for open food product
- Compressor available on left or right, specify at time of unit order
- Balanced forced-air refrigeration system provides rapid chilling of product



BB48HC-1-F-GS-B-27

### OPTIONS & ACCESSORIES

- 3"-6" casters or 6" legs
- Wine model (40°-60° models)
- Wine racks
- Pass-thru models available
- Underbar models available

### REFRIGERATION SYSTEM

- Refrigeration system uses R290 refrigerant to comply with all
- Automatic, non-electric evaporator
- Epoxy coated evaporator coil



3779 Champion Blvd., Winston-Salem, NC 27105  
1-888-845-9800 Fax: 1-336-245-6453  
Beverage-Air.com sales@bevair.com



# BEVERAGE-AIR

## Bar Equipment-Back Bar Refrigerator Sliding Glass Doors Food Rated

Model: BB48HC-1-F-GS-B-27, BB48HC-1-F-GS-S-27

MODEL	BB48HC-1-F-GS-B-27	BB48HC-1-F-GS-S-27
<b>EXTERNAL DIMENSIONAL DATA</b>		
Width Overall	48"	48"
Depth Overall	23 3/4"	23 3/4"
Height Overall	36"	36"
Number of Doors	2	2
Door Opening (in)	17" x 26 1/4"	17" x 26 1/4"
Shelf Area (sq. in.)	307 3/64"	307 3/64"
<b>INTERNAL DIMENSIONAL DATA</b>		
NET Capacity (cubic ft.)	12.4	12.4
Internal Width Overall (in)	36 1/4"	36 1/4"
Internal Depth Overall (in)	18 1/4"	18 1/4"
Internal Height Overall (in)	28"	28"
Number of Shelves	4	4
Number of Kegs	2	2
<b>ELECTRICAL DATA</b>		
Full Load Amperes 115/60/1	2.5	2.5
<b>REFRIGERATION DATA</b>		
Horsepower	1/4	1/4
Capacity (BTU/Hr)*	1702	1702
<b>WEIGHT DATA</b>		
Gross Weight (Crated lbs)	284 lbs	300 lbs
Height - Crated	43"	43"
Width - Crated	51"	51"
Depth - Crated	27"	27"

### Model Views

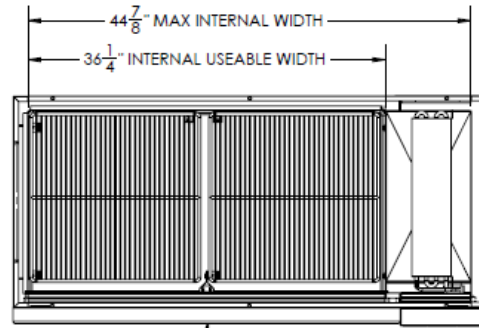

### Plan View

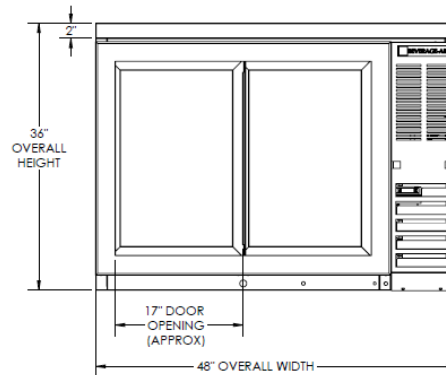

### Elevation View

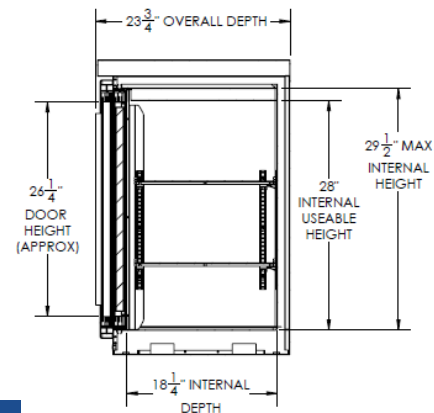

### Side View

### ELECTRICAL CONNECTION



115/60/1  
NEMA-5-15P

Units pre-wired at  
factory and include 8'  
long cord and plug set.

