

Item No. _____
Quantity _____



BEVERAGE-AIR

3779 Champion Blvd., Winston-Salem, NC 27105
1-888-845-9800 Fax# 1-336-245-6453
<http://www.Beverage-Air.com>

CUSTOMER'S CHOICE FOR A *HOT* KITCHEN
Tested & Certified to Ambient Class of 100°F

BOTTOM MOUNTED REACH-IN REFRIGERATORS

Horizon Series
Glass and Half Glass Doors

MODEL:
HBR23-1-G / HBR23-1-HG
HBR27-1-G / HBR27-1-HG
HBR44-1-G / HBR44-1-HG
HBR49-1-G / HBR49-1-HG
HBR72-1-G / HBR72-1-HG

3 Year Parts/Labor Warranty Additional 2 Year Compressor Warranty

CABINET CONSTRUCTION

- Exterior—Stainless steel interior and exterior standard.
- Insulation—foamed-in-place CFC and HCFC-free polyurethane insulation.
- One-piece grille allows easy removal/installation for preventative maintenance.

ELECTRONIC CONTROL

- Electronic thermostat provides a digital display of cabinet temperatures, which includes status indicators and key pad for any necessary temperature adjustments.

REFRIGERATION SYSTEM

- Bottom mount balanced refrigeration system for better ergonomics.
- Automatic condensate evaporation system for energy efficiency.
- Forced-air system ensures uniform distribution of airflow throughout the entire cabinet for even product temperatures; maintains product temperatures between 36 - 38°F.
- Self-contained refrigeration system uses environmentally friendly (CFC and HCFC-free) R134A refrigerant.

DOORS

- Choose from full glass or half glass door configuration.
- Anti-microbial door handles
- Spring-loaded hinges standard. Positive seal self-closing door(s) with 120° stay open feature.
- Plug-in magnetic door gaskets of one piece construction, removable without tools for ease of cleaning.

SHELVING

- Three (3) heavy duty epoxy coated wire shelves per section standard. Four (4) shelf clips included per shelf (field installed).
- Shelves are adjustable in 1/2" increments.

MODEL FEATURES

- LED lighting option standard
- 6" heavy-duty casters included, two with brakes standard. 3" casters or 6" legs optional.
- Pre-wired plug for 115/60/1 phase.
- Epoxy coated evaporator prevents corrosion.
- UL-EPH and CUL for open food product.



HBR23-1-HG

Available From:



*Note: Not all markings may apply to all model variations.

Model Specified _____	Store# _____
Location _____	Quantity _____



BEVERAGE-AIR

Horizon Bottom Mount Refrigerators
Models: HBR23, HBR27, HBR44, HBR49, HBR72

MODEL	HBR23	HBR27	HBR44	HBR49	HBR72
EXTERNAL DIMENSIONAL DATA					
Length Overall (inches)	27 1/4"	30"	47"	52"	75"
Length Overall (mm)	692	762	1193	1321	1905
Depth Overall (inches) - includes handle	33 3/4"	33 3/4"	33 3/4"	33 3/4"	33 3/4"
Depth Overall (mm) - includes handle	857	857	857	857	857
Height Overall—(inches) / (mm) Add 6" for legs or casters	78" / 1981	78" / 1981	78" / 1981	78" / 1981	78" / 1981
Number of doors	1	1	2	2	3
Depth with Door Open 90 °	60"	60"	60"	60"	60"
INTERNAL DIMENSIONAL DATA					
NET Capacity (cubic ft.)	23	27	44	49	72
NET Capacity (Liters)	651	765	1246	1388	2039
Internal Length Overall (inches)	24"	27"	47"	49"	72"
Internal Length Overall (mm)	610	686	1194	1245	1829
Internal Depth Overall (inches)	28 1/2"	28 1/2"	28 1/2"	28 1/2"	28 1/2"
Internal Depth Overall (mm)	724	724	724	724	724
Internal Height Overall—(inches)	61 3/4"	61 3/4"	61 3/4"	61 3/4"	61 3/4"
Internal Height Overall—(mm)	1569	1569	1569	1569	1569
Number of shelves	3	3	6	6	9
ELECTRICAL DATA					
Full Load Amperes 115/60/1	5.8 A	5.8 A	8.8 A	8.8 A	9.9 A
REFRIGERATION DATA					
Horsepower	1/3	1/3	1/3	1/3	1/2
WEIGHT DATA					
Gross Weight (Crated lbs)	400	400	528	608	771
Gross Weight (Crated kg)	181	181	239	276	350

PLAN VIEWS

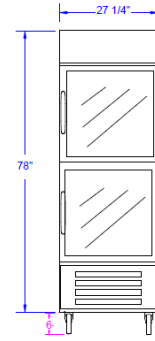

HBR23-1-HG

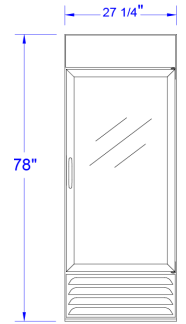

HBR23-1-G

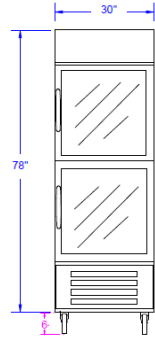

HBR27-1-HG

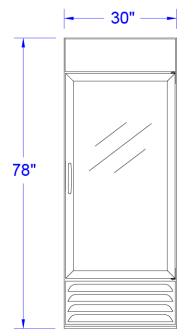

HBR27-1-G

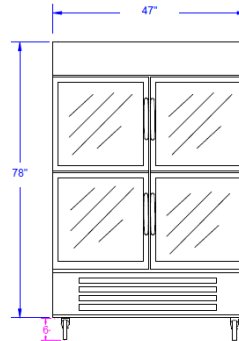

HBR44-1-HG

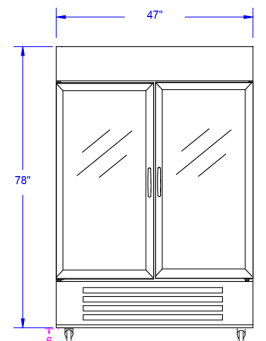

HBR44-1-G



Note: Not all markings may apply to all model variations.

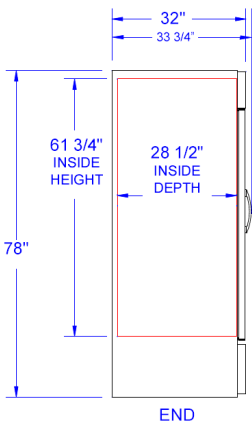

END

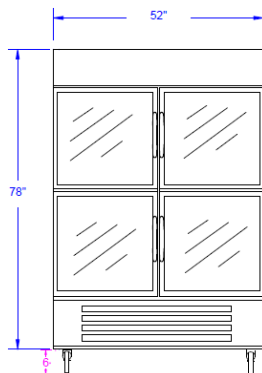

HBR49-1-HG

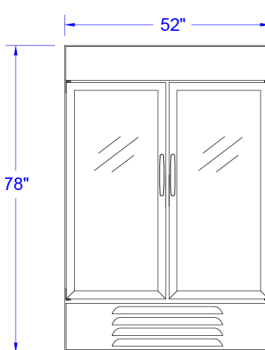

HBR49-1-G

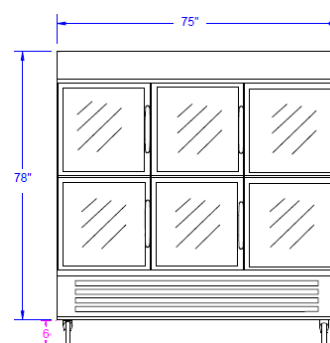

HBR72-HG

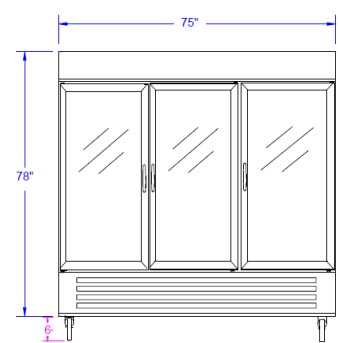

HBR72-G

BEVERAGE-AIR® CORPORATION

3779 Champion Blvd. • Winston-Salem, NC 27105 USA • (336) 245-6400 • Fax (336) 245-6453 • (888) 845-9800 • www.beverage-air.com

Specifications are subject to change without prior notice. 03/17