



www.santos.fr

**NEW GENERATION  
CENTRIFUGAL JUICE EXTRACTOR**  
"Miracle Edition" #68

**Best performance**

**Unsurpassed reliability**

**Extreme simplicity**



**NEW**

Miracle Edition: **THE DREAM COMESTRUE**  
**THE BEST JUICER THE MARKET HAS EVER HAD**  
Our goal: to offer the must-have appliance to juice bars specialists!

Internationally patented models





## NEW GENERATION CENTRIFUGAL JUICE EXTRACTOR "Miracle Edition" #68

### NEW DESIGN FOR MORE EFFICIENCY

The centrifugal juice extractor **"Miracle Edition" #68** is the result of Santos 60 years worldwide experience. The Miracle Edition offers you high efficiency with an innovative design. More powerful, more robust and easier to clean, this new generation juice extractor is dedicated to juice bars, health food stores, hotels, bars, restaurants, cafeterias, ice cream shops, institutions...

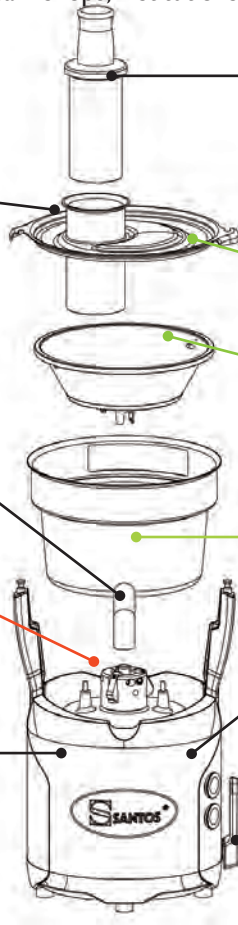

**Extra wide feeding chute:**  
Ø 79.5 mm (3")  
No need to cut fruits or vegetables

**Spout height:** 228 mm  
Accepts glasses, jugs and blender jars

**NEW Patented Ezy-clean™ system II :**  
Removable bowl, basket and cover (no tool needed). Reliable and robust, perfect locking of the basket



Stainless steel and aluminium body



**Output**  
Up to **140** liters of juice per hour (200kg/h)

**Pusher:** Low effort, constant flow, maximum yield

**FULL STAINLESS STEEL FOOD ZONE (NO ALUMINIUM):**

**Stainless Steel Cover** **NEW**

**Stainless Steel Filter Basket:** **NEW**  
Easy to remove. Obtain a perfect filtration thanks to its very fine sieve (0.5 mm/0.02" holes). Basket with 0.8 mm holes available on demand

**Stainless Steel Bowl**

**Powerful:** Asynchronous motor extremely silent and powerful (1300W)

**Safety:** Locking - unlocking patented system  
Electric cut-off and motor breaking when opening the handle



A cleaning brush and a soft drip tray are delivered with the appliance.

### THE FULL JUICE BAR SOLUTION

Santos is the specialist of the professional juicing since 1954 and the only manufacturer in the world to provide **THE FULL JUICE BAR SOLUTION:** Citrus Juicers + Juice Extractors + Blenders!



**Santos**  
Worldwide leader in commercial juicers

## "EZY-CLEAN™ SYSTEM II" #68



## RELIABILITY, STURDINESS, PERFORMANCE

www.santos.fr

- **Full stainless steel food-zone:** no aluminium
- **Easiness:** new generation patented **Ezy-Clean System II** which saves your time (you can easily remove the cover, bowl and basket thanks to their new ergonomics). Extremely sturdy: no plastic in the shifter area.
- **Comfort:** no need to cut apples, carrots, tomatoes... thanks to the wide feeding chute (Ø79.5 mm)
- Even more efficiency: **output up to 140 l/h**, motor and baskets are calibrated, rotating at the ideal speed to extract a maximum juice
- **Perfect filtration** high quality juice without any fruit pulp, even for intensive use
- **Preservation of vitamins:** keeps all the vitamins from fruits and vegetables.



### Juice bar version #68J:

This juicer is **delivered with a pulp tube**, which goes directly through your counter to the waste collector below.



### Chefs and Patisserie kit #68 I I 0:

Filtration basket with 0.8mm holes, for more creamy coulis, and for fiber fruits (ex: pineapple)

- **I wide feed tray** to place fragile fruits, or pour liquid preparations...



## TECHNICAL SPECIFICATIONS



### Motor

Single phase: 100-120V – 50/60 Hz – 1300W – CE, NSF, UL  
220-240V – 50/60 Hz – 1300W – CE, NSF

Speed: 3000 rpm (50 Hz)  
3600 rpm (60 Hz)



### Weight

Net: 25Kg (55 lbs)  
Shipping: 28 Kg (62 lbs)



### APPLIANCE

W: 330 mm / 13"  
D: 562 mm / 22"  
H: 606 mm / 24"

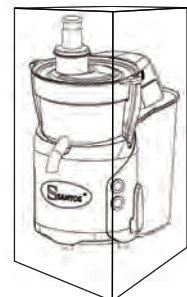

### SHIPPING BOX

W: 390 mm / 15.4"  
D: 660 mm / 26"  
H: 600 mm / 23.6"

## SAFETY, STANDARDS, HYGIENE

### In accordance with the following regulations

- Machinery directive 2006/42/EC
- Electromagnetic compatibility 2004/108/EC
- Electrical equipment designed for use within certain voltage limits "low voltage" 2006/95/EC
- RoHS directive 2002/95/EC
- Regulation 1935/2004/EC (contact with food)

### Harmonized European standards

- EN ISO 12100 - 1 and 2: 2004
- EN 60204-1: 2006
- EN 12547+A1: 2009 Juice extractors
- EN 60335-2-64: 2004 Commercial electric kitchen machines

CE (European standards), NSF (USA), UL (USA) and cUL (Canada)

### Thermal safety

Motor protected by thermal detector and overload protector.

### Electrical safety

- On/ off switch detects no voltage.
- All mechanical parts are ground connected.
- Appliances are 100% tested after assembly.

### Acoustic safety

Silent asynchronous motor.

### Mechanical safety

A friction brake immediately stops the basket when opening the handle.

### Hygiene

All removable parts can be put in a dishwasher or easily cleaned with hot soapy water.

**PRODUCT: 2-YEAR WARRANTY | MOTOR: 5-YEAR WARRANTY**

# NEW GENERATION CENTRIFUGAL JUICE EXTRACTOR

"Miracle edition" #68



www.santos.fr

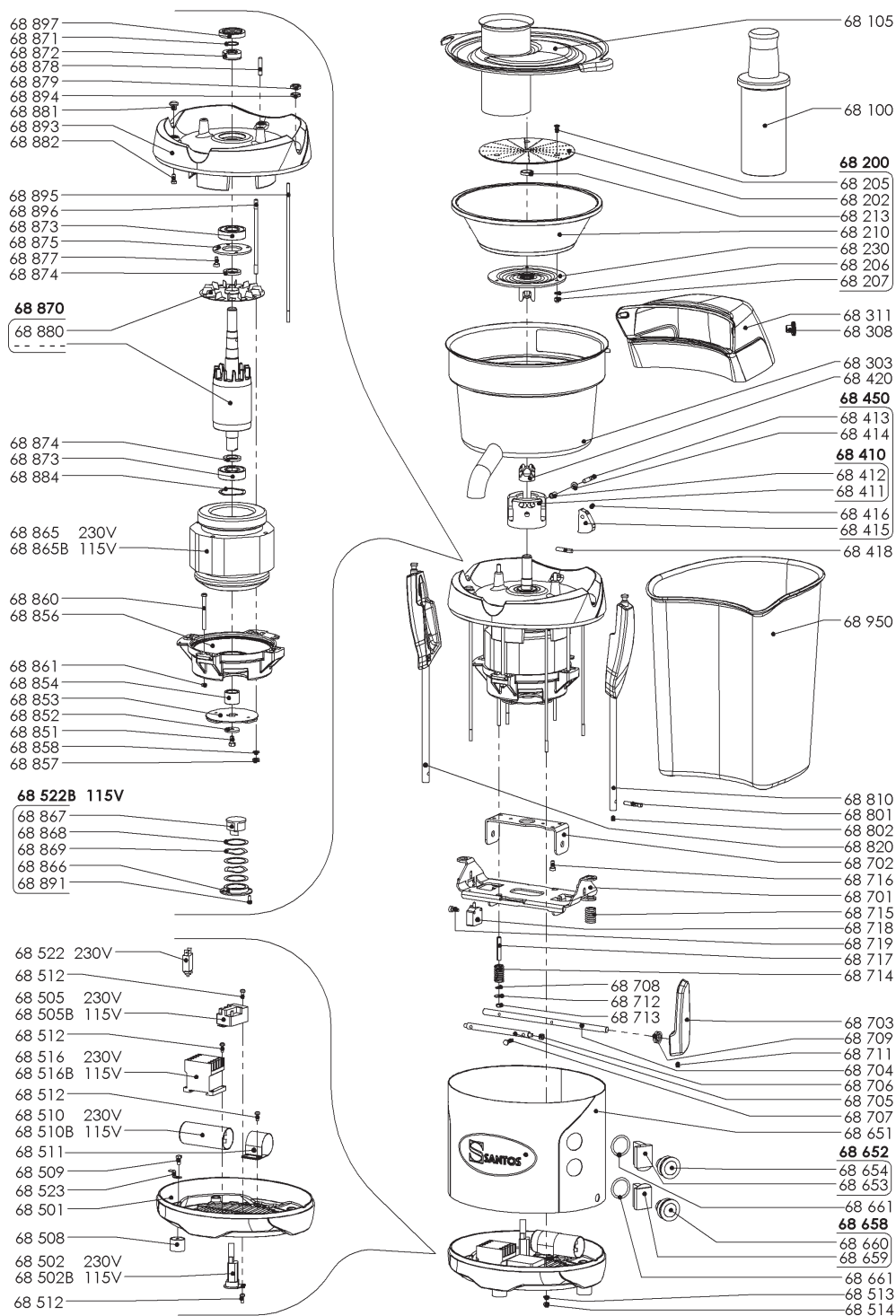

**SANTOS**

140-150, avenue Roger Salengro BP 80 067 - 69511 Vaulx-en-Velin Cedex (Lyon) FRANCE – Tel. +33 4 72 37 35 29 – Fax. +33 4 78 26 58 21

Website : [www.santos.fr](http://www.santos.fr) – Email : [santos@santos.fr](mailto:santos@santos.fr)

I1/2015 – V4