



4184 E. Conant st., Long Beach, CA 90808
 Tel. 800-500-3519 Fax. 310-900-1066
www.gkradiance.com

Project :

Model # :

Item # :

Qty :

Available W/H :

Approval :

Cheesemelters

Model : TACM-36



≡ FEATURES & BENEFITS ≡

- *Stainless steel front, sides and interior*
- *Adjustable gas valve*
- *Protective screen over infra-red burner*
- *Chrome plated heavy duty rack*
- *Unit can be mounted over Radiance range, counter and also on a wall*
- *CSA certified for safety / sanitation for USA and Canada*



Model	Weight (lbs.)	Length (inches)	Total BTUs
TACM-36	162	36	35,000
TACM-36-LP	162	36	35,000

Cheesemelters

Model : TACM-36

DATA	TACM-36	TACM-36-LP
Gas Type	NAT	LPG
Gas Connection	3/4"	3/4"
Regulator	1	1
Gas Pressure	5.W.C"	10.W.C"
BTU	35,000	35,000
DIMENSIONAL DATA		
Ext. Length Overall (inch)	36 (914mm)	36 (914mm)
Ext. Depth Overall (inch)	20 1/2 (519mm)	20 1/2 (519mm)
Ext. Height Overall (inch)	19 (483mm)	19 (483mm)
Weight (lbs.)	162	162

Design and specifications subject to change without notice.
Actual shipping weight may differ due to extra packing materials for product protection.

■ WARRANTY : 1 Year Parts and Labor Warranty

PLAN VIEW

(unit : inch)

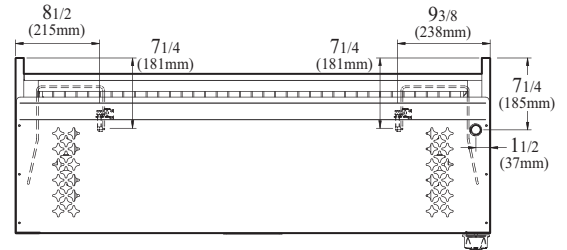

TOP VIEW

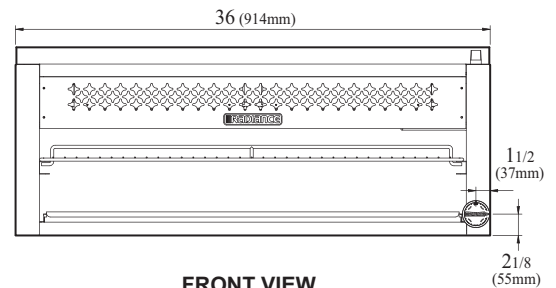

FRONT VIEW

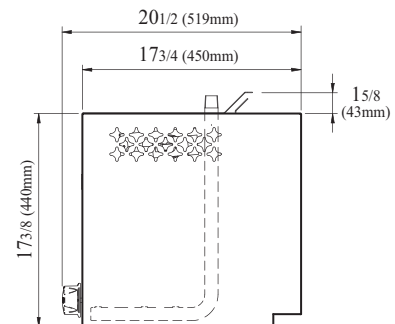

SIDE VIEW

Ver.201606



- Turbo Air : 800-627-0032 ■ GK : 800-500-3519
- Warranty : 800-381-7770 ■ AC : 888-900-1002