



4184 E. Conant st., Long Beach, CA 90808  
 Tel. 800-500-3519 Fax. 310-900-1066  
[www.turboairinc.com](http://www.turboairinc.com)

Project :

Model # :

Item # :

Qty :

Available W/H :

Approval :

## Cheesemelters

**Model : TACM-48**



### ≡ FEATURES & BENEFITS ≡

- *Stainless steel front, sides and interior*
- *Adjustable gas valve*
- *Protective screen over infra-red burner*
- *Chrome plated heavy duty rack*
- *Individual left and right gas controls*
- *Unit can be mounted over Radiance range, counter and also on a wall*
- *CSA certified for safety / sanitation for USA and Canada*



Model	Weight (lbs.)	Length (inches)	Total BTUs
TACM-48	208	48	40,000
TACM-48-LP	208	48	40,000

# Cheesemelters

## Model : TACM-48

DATA	TACM-48	TACM-48-LP
Gas Type	NAT	LPG
Gas Connection	3/4"	3/4"
Regulator	1	1
Gas Pressure	5.W.C"	10.W.C"
BTU	40,000	40,000
<b>DIMENSIONAL DATA</b>		
Ext. Length Overall (inch)	48 (1219mm)	48 (1219mm)
Ext. Depth Overall (inch)	20 1/2 (519mm)	20 1/2 (519mm)
Ext. Height Overall (inch)	19 (483mm)	19 (483mm)
Weight (lbs.)	208	208

Design and specifications subject to change without notice.  
Actual shipping weight may differ due to extra packing materials for product protection.

### ■ WARRANTY : 1 Year Parts and Labor Warranty

## PLAN VIEW

(unit : inch)

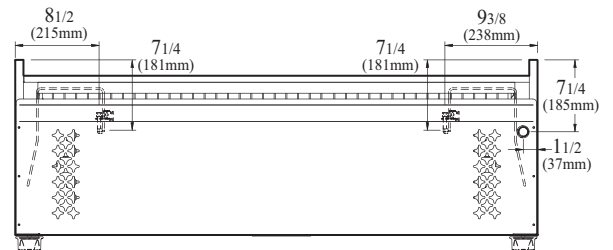

TOP VIEW

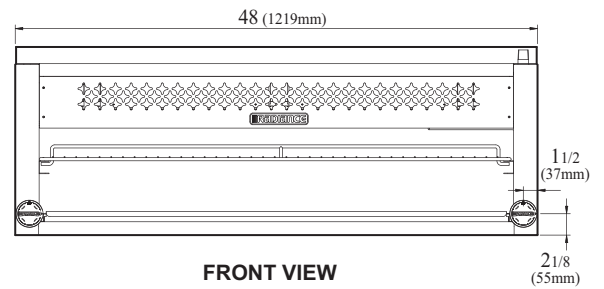

FRONT VIEW

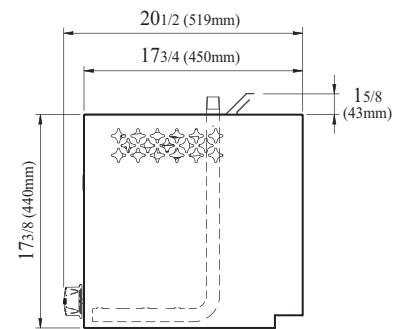

SIDE VIEW

Ver.201601



- Turbo Air : 800-627-0032 ■ GK : 800-500-3519
- Warranty : 800-381-7770 ■ AC : 888-900-1002