



**TRUE FOOD SERVICE
EQUIPMENT, INC.**

2001 East Terra Lane • O'Fallon, Missouri 63366-4434 • (636)240-2400
 Fax (636)272-2408 • Toll Free (800)325-6152 • Intl Fax# (001)636-272-7546
 Parts Dept. (800)424-TRUE • Parts Dept. Fax# (636)272-9471 • www.truemfg.com

Project Name: _____

Location: _____

Item #: _____ Qty: _____

Model #: _____

A/A #

S/S #

Model:
TCGD-59

Display Case:
Curved Glass Dry Bakery Case



TCGD-59

- ▶ True's non-refrigerated "dry" display case combines efficient, high volume merchandising with an elegant curved glass front for sophisticated presentation of breads, desserts and pastries.
- ▶ Single pane curved glass front and side panels provide extra large viewing area to maximize bakery product presentation. Front glass tilts forward for easy cleaning.
- ▶ Three (3) adjustable PVC coated shelves.
- ▶ Special "brown bulb" lighting provides balanced color spectrum that enhances the appearance of bakery products.
- ▶ Exterior front and sides standard with white laminate panels, five additional color options available at no charge. Stainless steel top.
- ▶ White aluminum interior sides and top. High impact plastic floor with covered corners.

ROUGH-IN DATA

Specifications subject to change without notice.
 Chart dimensions rounded up to the nearest 1/8" (millimeters rounded up to next whole number).

Model	Doors	Shelves	Cabinet Dimensions (inches)			Voltage	Amps	Crated Weight (lbs.)
			L	D†	H			
TCGD-59	2	3	59 7/8 1521	35 1/2 902	47 7/8 1217	115/60/1	5.9 N/A	530 241

† Depth does not include 3/4" (18 mm) for door handles.
 note: Standard Dry Bakery Cases require hard wiring.
 Optional, factory installed, 12" cord set available (exterior scale receptacle will not be included with this option; upcharge applies).

	APPROVALS:	AVAILABLE AT:
	3/15 Printed in U.S.A.	

Model:
TCGD-59

Display Case: Curved Glass Dry Bakery Case



STANDARD FEATURES

DESIGN

- True's "dry" display case combines efficient, high volume merchandising with an elegant curved glass front for sophisticated presentation of breads, desserts and pastries.
- Designed to provide an attractive companion to our forced-air refrigerated display case.

CABINET CONSTRUCTION

- Exterior - white laminate front and side panels. Color options available at no charge (upcharge for stainless steel):

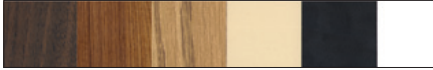

Walnut | Teak | Oak | Beige | Black | White

- All laminate (and stainless option) ships separately from unit and is field installed. Stainless steel top. Black front and rear grills and trim. Custom template kit available at no charge for field installation of laminate.
- Interior - NSF approved white aluminum sides and top; high impact plastic floor with coved corners.
- Welded, heavy duty steel frame rail, black powder coated for corrosion protection.
- Frame rail fitted with leg levelers.

CURVED FRONT DISPLAY GLASS

- Single pane curved glass front and side panels provide extra large viewing area to maximize bakery product presentation. Glass is tempered for safety.
- Front glass tilts forward for easy cleaning.

REAR DOORS

- "Low-E", double pane thermal glass rear door inserts with mitered plastic channel frames.
- Each door fitted with 12" (305 mm) long molded plastic handle.

- Self-closing doors, efficient counter balanced weight system for smooth, even, positive closure. Sliding doors ride on stainless steel V-channel with stainless steel bearings. Doors fit within plastic channel frame.

SHELVING

- Three (3) adjustable, heavy duty PVC coated wire shelves 53³/₁₆"L x 22⁵/₃₂"D (1356 mm x 563 mm). Shelving system is cantilevered and angle can be adjusted to maximize presentation.
- Each shelf supports a maximum weight of 150 lbs. (69 kg).

PAN CAPACITY

- Cabinet holds twelve (12) 18"L x 26"D (458 mm x 661 mm) display pans (3 per level). Pans supplied by others.

LIGHTING

- Cabinet equipped with four (4) light sources for maximum product display; three (3) shelf mounted and one (1) cabinet mounted. Special "brown bulb" lighting provides balanced color spectrum that enhances the appearance of bakery products.
- Safety shielded lighting tubes assure longer, brighter, shadow-free product illumination.

MODEL FEATURES

- Five (5) amp exterior scale receptacle.
- Recessed exterior light switch.
- NSF-2 compliant for open food product.

ELECTRICAL

- Unit comes with 4 feed wires (including ground) to be hardwired at installation site to a 115/60/1 phase, 15 amp dedicated outlet.

OPTIONAL FEATURES/ACCESSORIES

Upcharge and lead times may apply.

- 6" (153 mm) standard legs.
- 6" (153 mm) seismic/flanged legs.
- 2¹/₂" (64 mm) diameter castors [NOTE: castors can not be installed on units that are hardwired, optional 12" (305 mm) power cord must be factory installed].
- 12" (305 mm) cord set (factory installed). Exterior scale receptacle will not be included with this option.
- Custom exterior laminates, contact factory for details. See our website: www.truemfg.com for the latest color offerings.
- Stainless steel exterior (field installed).
- Mirrored interior ends with laminate exterior.
- Additional lighted shelves.
- Additional non-lighted shelves.

PLAN VIEW

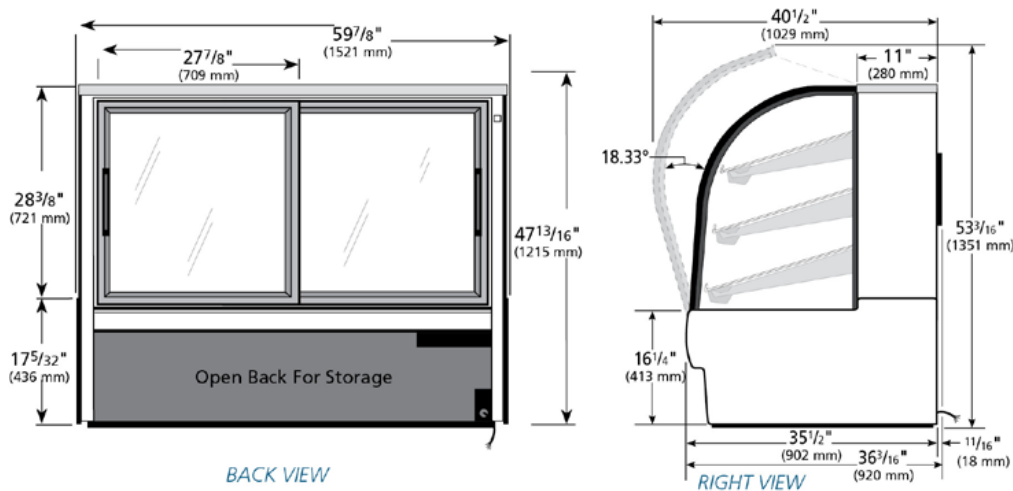

WARRANTY*

Three year warranty on all parts and labor. (U.S.A. only)

METRIC DIMENSIONS ROUNDED UP TO THE NEAREST WHOLE MILLIMETER

SPECIFICATIONS SUBJECT TO CHANGE WITHOUT NOTICE



Model	Elevation	Right	Plan	3D	Back
TCGD-59	TFD077E	TFD055S	TFD082P	TFD0823	TFD082B

*RESIDENTIAL APPLICATIONS: TRUE assumes no liability for parts or labor coverage for component failure or other damages resulting from installation in non-commercial or residential applications.

TRUE FOOD SERVICE EQUIPMENT

2001 East Terra Lane • O'Fallon, Missouri 63366-4434 • (636)240-2400 • Fax (636)272-2408 • Toll Free (800)325-6152 • Intl. Fax# (001)636-272-7546 • www.truemfg.com