

# tortillaXpress



Model No.

## TXM-15

## Manual Tortilla Press

The TXM-15 is an economic manual tortilla dough press, perfect for low to medium production volumes. It is a fast, safe, simple, mess free and the 15"x15" platen is capable of making 4 tortillas at once. The TXM-15 press is great for either flour or corn tortillas and flat breads. The TXM-15 is a swing away design with upper and lower heated platens.

### Dual Heated Platens:

- initial grill off for tortillas (fully grilling on press not recommended)
- speeds up production (faster pressing times)
- enables pressing thinner products
- aids dough flow
- allows dough to be pressed straight from refrigeration unit

### Pressing Tips:

(Pre-Grill)

- Recommended Time:  
1-3 seconds
- Recommended Temperature:  
275°-300°

### Labor:

- presses require no skilled labor unlike hand tossing
- presses are safe and have no age requirements unlike sheeters/rollers

### Variable Thickness Control

- makes it possible to achieve desired thickness and ensures consistent thickness at the same dough ball weight

### Production:

- 15"x15" platen allows for making variable tortilla sizes and thicknesses up to 16 inches in diameter – the size of the tortilla is determined by the weight of the dough ball and the thickness setting.
- depends on the desired size of the tortilla...  
8" to 15" = 75-100/hr,  
7" = 150-200/hr,  
6" or under = 300-400/hr

### Finished Product:

- pressed dough is consistent in thickness and size vs. hand prepared where the thickness and size can be inconsistent.
- for best results, we recommend initial grill off of tortillas on dual-heated press and finish on DoughXpress Tortilla Warmer (TXW-1620, TXW-2025 or TXW-2540)

### Use:

- TXM-15 is easy to use... prepare dough balls, set temp/thickness, place dough ball in center of lower platen, and press the dough.



**doughXpress**

**HIX Corporation Food Division**

Product improvement may require us to change specifications without notice.

Revised March 2012

**DOUGHXPRESS**

1201 E. 27th Terrace  
Pittsburg, KS 66762 USA

Toll Free: (800) 835-0606 ext.205

Tel: (620) 231-8568 ext.205

Fax: (620) 231-1598

[doughxpress@hixcorp.com](mailto:doughxpress@hixcorp.com) or visit [www.doughxpress.com](http://www.doughxpress.com)

# tortillaXpress



Model No.

## TXM-15

## Manual Tortilla Press

### Features Include:

- full range thickness adjustment from paper thin to 7/8"
- easy to use open and close handle
- top platen swings away for easy loading and unloading of dough
- heat indicating light that turns off when set temperature is reached
- flattens dough balls into pizzas up to 18" in diameter
- powder coated white finish with aluminum upper and lower platens

### Optional Features:

- Non-stick PTFE coated upper and lower platens

### Certifications:

- ETL
- NSF Listed
- ETL Canadian Standard

### Recommended Cleaning Instructions:

- wipe down with a moist towel - if needed, use damp sponge with minimal soap and water and then dry off

### DIMENSIONS

Width: 16-1/2 inches, 41.91 centimeters  
Height: 15-1/4 inches, 38.74 centimeters  
Depth: 24 inches, 60.96 centimeters

### WEIGHT

Shipping: 85 lbs.

### ELECTRICAL

220 Volts / 50-60 Hz  
3100 Watts  
15 Amps  
6-20P NEMA Plug

### TEMPERATURE RANGE

Off-400°F, 204°C upper platen

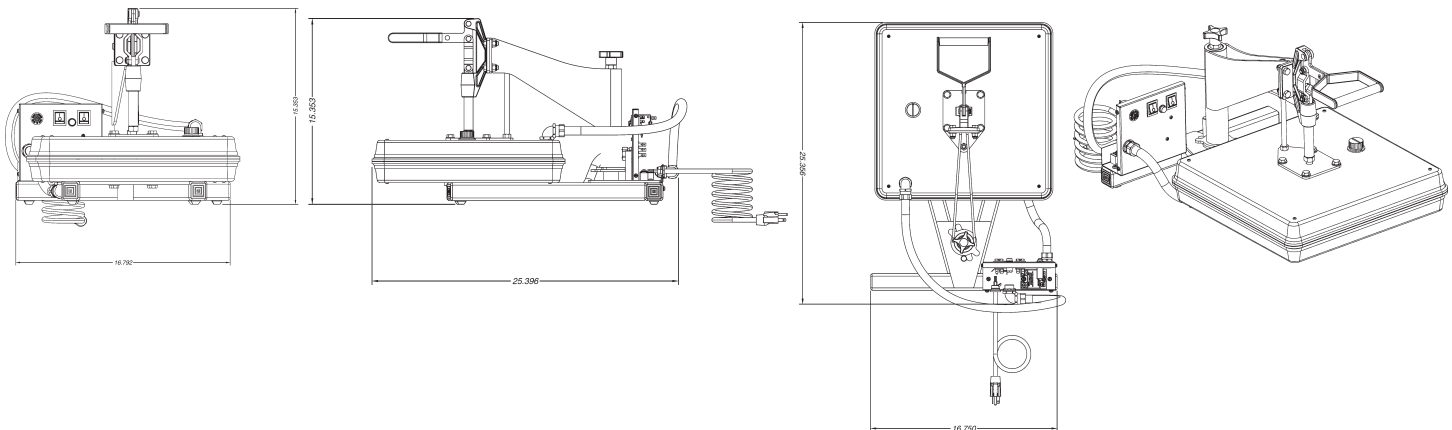

## doughXpress

**HIX Corporation Food Division**

Product improvement may require us to change specifications without notice.

Revised March 2012

**DOUGHXPRESS**

1201 E. 27th Terrace  
Pittsburg, KS 66762 USA

Toll Free: (800) 835-0606 ext.205

Tel: (620) 231-8568 ext.205

Fax: (620) 231-1598

[doughxpress@hixcorp.com](mailto:doughxpress@hixcorp.com) or visit [www.doughxpress.com](http://www.doughxpress.com)