



PROJECT _____
 ITEM # _____
 QUANTITY _____



SEAMLESS INNER TANK
 corrosion proof • easy cleaning
 round edge • hygienic design &
 construction



AX-GPC-1

AX-GPC-2

Our pasta cookers are among the kitchen's most reliable and trusted equipment. Chefs world-wide use them to cook fresh or dry pasta, as well as rice, vegetables, potatoes, and seafoods or just to rethermalize. This self-contained cooking system eliminates the dangerous handling of heavy pots containing boiling water. As an option, solid pans can be inserted into the cooking chamber to hold sauces.

GAS PASTA COOKER - STANDARD FEATURES (both models)

- ★ All heavy-duty stainless steel construction meeting NSF requirements
- ★ One piece deep drawn inner tank #304 stainless steel for ease of maintenance
- ★ Inner tank is corrosion-proof from the effects of salt water and is a hygienic design
- ★ Piezo-electric ignition
- ★ Overflow area safeguards against accidental overflow
- ★ High efficiency burner technology concentrating greater heat at the rear creating a convective flow of water eliminating the need for stirring which shortens cook times
- ★ Energy and time saving mechanism
- ★ Assorted combination of stainless steel mesh baskets with ergonomic positioned handle are included
- ★ Gas injector nozzles provided to switch from Natural to LP gas
- ★ Batter plate
- ★ Bottom-front connection
- ★ Manual gas shut-off valve
- ★ Water inlet, 1" full port drain valve & High capacity overflow drain
- ★ Cooking time: 5-10 min.
- ★ 6" adjustable stainless steel legs

AXIS SINGLE & DOUBLE GAS PASTA COOKER





TECHNICAL DRAWINGS

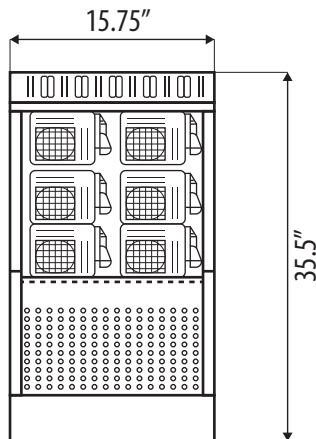
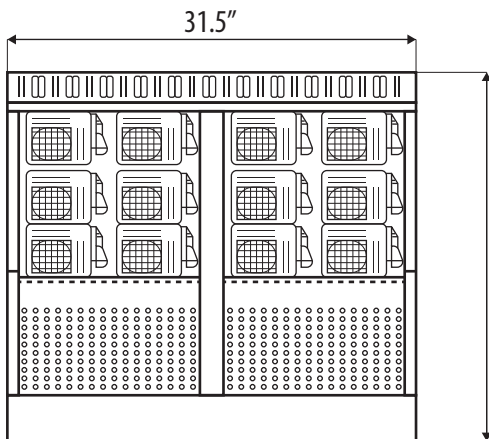
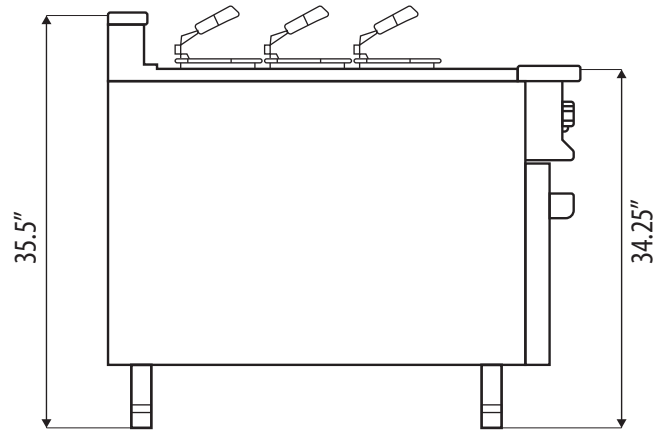
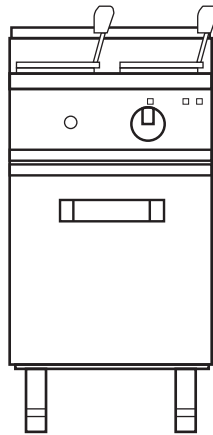
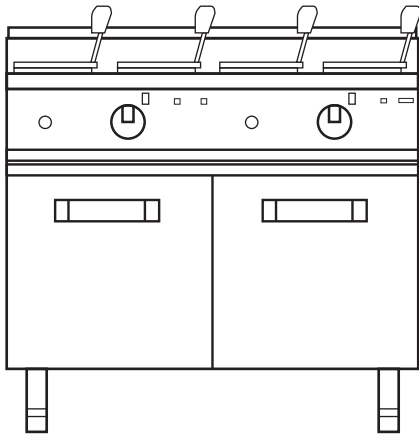

AVAILABLE BASKETS:



AX-PCBA
5.5" X 5.5" X 7.9"



AX-PCBB
3.1" X 11" X 9.1"

SPECIFICATIONS

	CAPACITY	HEAT INPUT (Btu/h)	CONSUMPTION	GAS CONNECTION	DIMENSIONS (W X D X H)	OVERALL WORKING HEIGHT	GAS PRESSURE	NET WEIGHT
AX-GPC-1	88 LBS	61416	Natural gas: 1.92 yd3/h Propane: 2.38 lb/h	1/2" NPT	15.75" X 35.5" X 33.4"	34.25"	Natural gas: 7" WC Propane gas: 11" WC	165 LBS
AX-GPC-2	176 LBS	122832	Natural gas: 3.85 yd3/h Propane: 4.76 lb/h	1/2" NPT	31.5" X 35.5" X 33.4"	34.25"	Natural gas: 7" WC Propane gas: 11" WC	287 LBS

WARRANTY: 12 MONTHS PARTS & LABOR, 60 MONTHS ON INNER TANK.

Axis is a registered trademark of MVP Group.

Due to continuing product development, to ensure best possible performance, the specifications are subject to change without prior notice.

Tel.: 514.737.9701 / Toll Free: 888.275.4538
 Fax: 514.342.3854 / Toll Free: 877.453.8832
 sales@mvpgroupcorp.com • www.mvpgroupcorp.com

