

GAS GRIDDLE

Project Date Models **GCP15, GCP24, GCP36, GCP48** Item# Quantity



model GCP48

Features

- Sleek, heavy-duty stainless steel construction for long life and easy maintenance
- All models can be operated using natural or LP gas (conversion kit included)
- Manually controlled, independent cooking zones
- Countertop units with 20" depth available in four widths: 15", 24", 36", and 48"
- Griddle plate thickness of $\frac{3}{4}$ "

Models & Dimensions

Gas Griddle

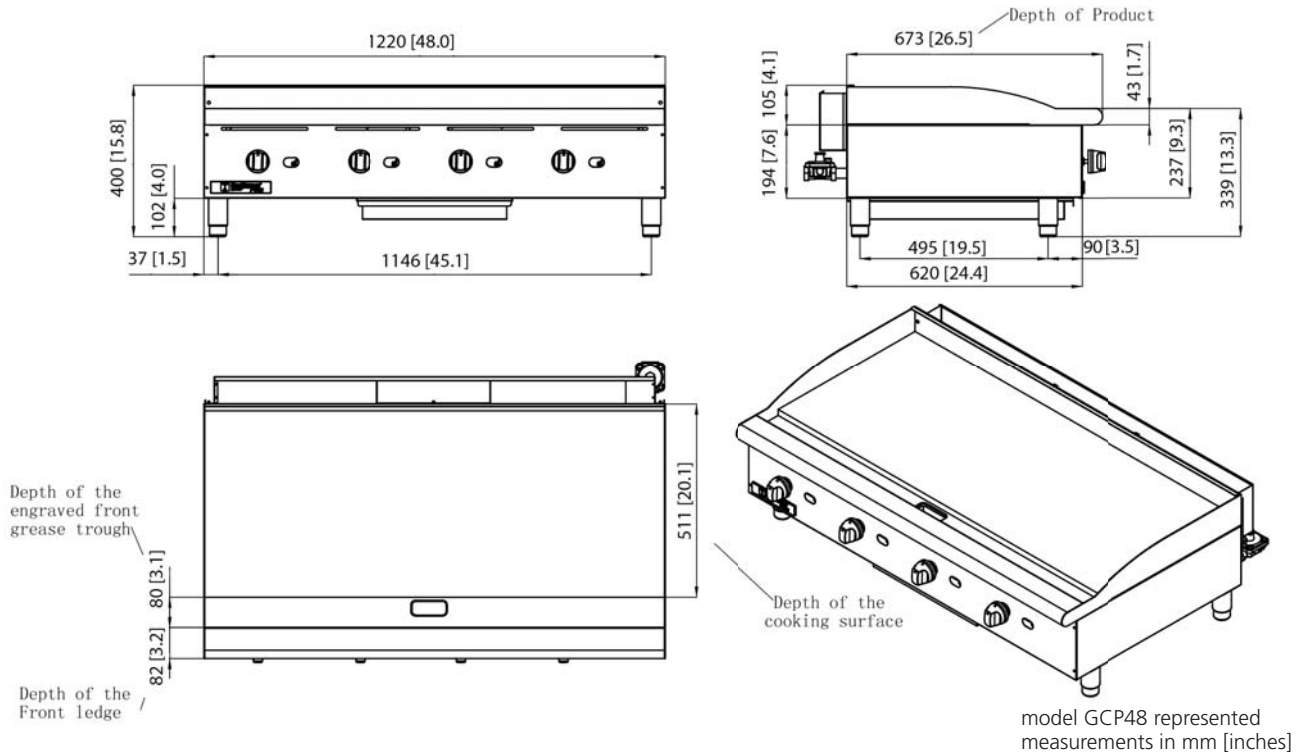

Specifications

| Model | Cooking Surface | No. of Burners | Power | Product Dimensions | Outer Carton Dimensions | Weight |
|-----------------------------|-------------------------------------|----------------|-----------------|---|---|---------------------|
| GCP15 (6601-1000) | 15" W x 20" D mm: 377 W x 510 D | One | 30,000 BTUs | 15.2" W x 32.3" D x 15.6" H mm: 386 W x 820 D x 396 H | 18.5" W x 32.5" D x 19.1" H mm: 470 W x 826 D x 485 H | 106 lbs. 48 kg. |
| GCP24 (6601-1001) | 24" W x 20" D mm: 606 W x 510 D | Two | 60,000 BTUs | 24.6" W x 32.3" D x 15.6" H mm: 610 W x 820 D x 396 H | 28.0" W x 32.5" D x 19.1" H mm: 711 W x 826 D x 485 H | 162 lbs. 73 kg. |
| GCP36 (6601-1002) | 36" W x 20" D mm: 911 W x 510 D | Three | 90,000 BTUs | 36.6" W x 32.3" D x 15.6" H mm: 915 W x 820 D x 396 H | 40.0" W x 32.5" D x 19.1" H mm: 1016 W x 826 D x 485 H | 231 lbs. 105 kg. |
| GCP48 (6601-1003) | 48" W x 20" D mm: 1216 W x 510 D | Four | 120,000 BTUs | 48.6" W x 32.3" D x 15.6" H mm: 1220 W x 820 D x 396 H | 52.0" W x 32.5" D x 19.1" H mm: 1321 W x 826 D x 485 H | 298 lbs. 135 kg. |

