

GAS HOT PLATE

Project Date Models **HPCP212, HPCP424, HPCP636** Item# Quantity



model HPCP636

Features

- Sleek, heavy-duty stainless steel construction for long life and easy maintenance
- All models can be operated using natural or LP gas (conversion kit included)
- Individually controlled burners
- Heavy duty cast iron trivets for a sturdy work surface
- Countertop units with 23.6" depth available in three widths:
 - 12" wide with 2 burners
 - 24" wide with 4 burners
 - 36" wide with 6 burners

Models & Dimensions

Gas Hot Plate

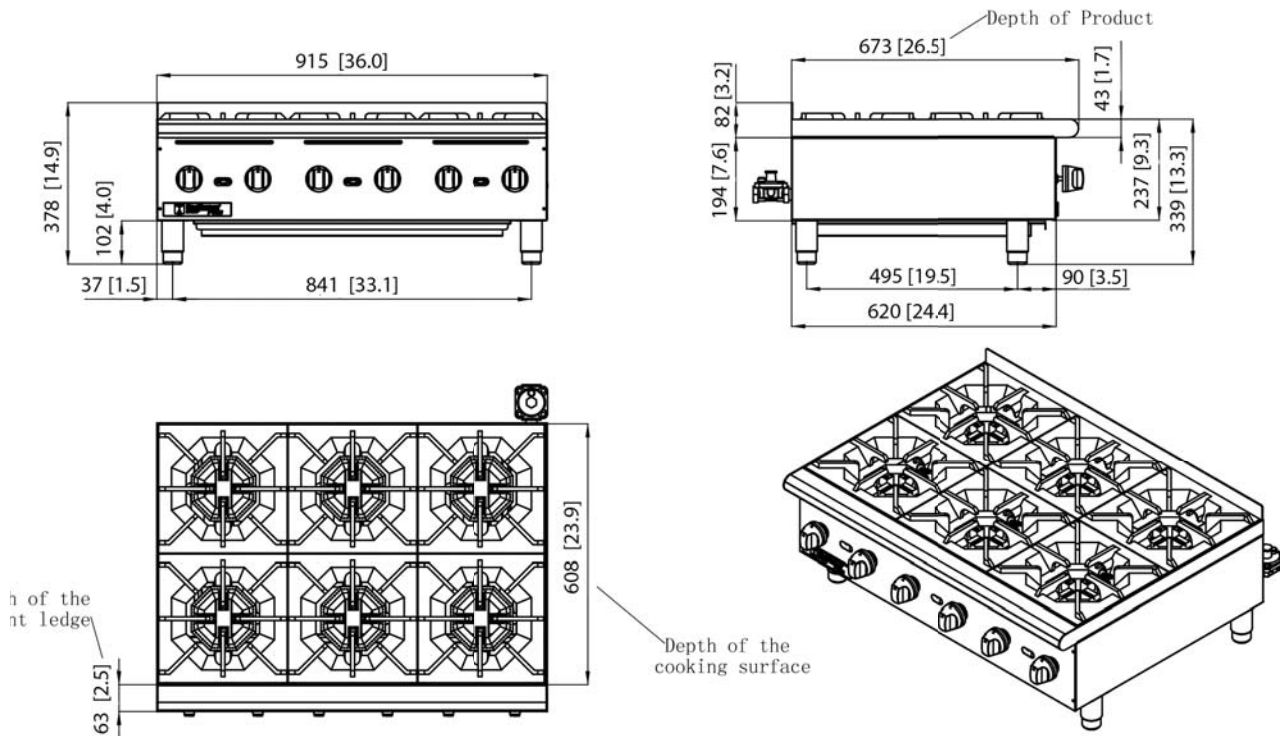

model HPCP636 represented measurements in mm [inches]

Specifications

| Model | Cooking Surface | No. of Burners | Power | Product Dimensions | Outer Carton Dimensions | Weight |
|-------------------------------|------------------------------------|----------------|-----------------|--|--|--------------------|
| HPCP212 (6200-2000) | 12" W x 20" D mm: 305 W x 510 D | Two | 44,000 BTUs | 12.0" W x 30.3" D x 13.4" H mm: 305 W x 770 D x 340 H | 16.65" W x 30.91" D x 17.99" H mm: 423 W x 785 D x 457 H | 70 lbs. 32 kg. |
| HPCP424 (6200-4000) | 24" W x 20" D mm: 606 W x 510 D | Four | 88,000 BTUs | 24.0" W x 30.3" D x 13.4" H mm: 610 W x 770 D x 340 H | 28.54" W x 30.91" D x 17.99" H mm: 725 W x 785 D x 457 H | 123 lbs. 56 kg. |
| HPCP636 (6200-6000) | 36" W x 20" D mm: 911 W x 510 D | Six | 132,000 BTUs | 36.0" W x 30.3" D x 13.4" H mm: 914 W x 770 D x 340 H | 40.67" W x 30.91" D x 17.99" H mm: 1033 W x 785 D x 457 H | 176 lbs. 80 kg. |

