



i n t r o d u c i n g

# a new generation of coolers MC750



## Features:

- Cartridge Refrigeration System
- Field Reversible, Hinged Door
- Recessed Pocket Door Handle



**BEVERAGE-AIR**

A Division of Carrier Commercial Refrigeration, Inc.

# MC750



**BEVERAGE-AIR**

A Division of Carrier Commercial Refrigeration, Inc.

## Standard Features:

- Cartridge refrigeration system
- HFC-free foam insulation
- Lighted signboard
- Vertical lighting with electronic ballast
- High-performance glass door - double-pane tempered glass with Low-E coating, argon gas filled
- Field-reversible, hinged door
- North America Certifications
- Self-closing door with hold-open feature
- Fully-adjustable shelving with flat or gravity-feed positions
- Light switch
- Mechanical temperature control
- Recessed pocket door handle

## Optional Features:

- Customized merchandising decals for sign header and side panels
- Upgraded base grille
- Door lock kit
- Caster kit
- Gravity organizer kit for shelves



20 Oz. Bottle	Facing	Depth	Shelves	Doors	Total Capacity Organized/Loose
	8	8	5	1	320/360

## SPECIFICATIONS

MODEL	CRATED WEIGHT	DOORS	40' CONTAINER QTY	53' TRUCK LOAD QTY	20 OZ. BOTTLE CAPACITY ORGANIZED/LOOSE	CU. FT.	SHELVES	SHELF SIZE INCHES W X D	OVERALL EXT. INCHES W X D X H	OVERALL EXT. METRIC (MM) W X D X H	VOLTAGE	AMPS	HP
MC750	377	1	39	51	320/360	26.5	5	21" X 18 3/4"	30" X 32" X 78"	762 X 813 X 1981	115	8.9	1/3

## CABINET DIMENSIONS

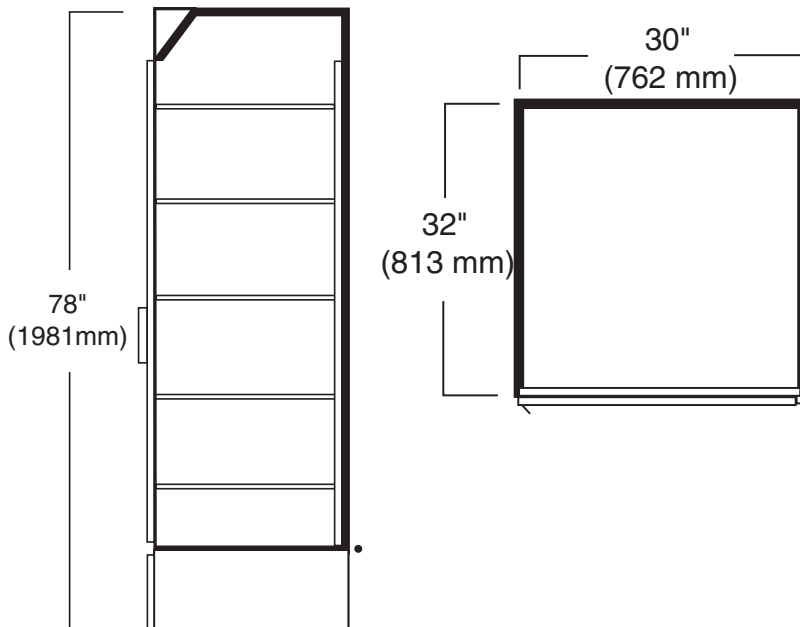

## SPECIFICATIONS-CARTRIDGE

MODEL	MC750 - Medium
SIZE (INCHES) W X D X H	23" X 24" X 12 3/4"
COMPRESSOR TYPE	HERMETIC, RECIPROCATING
COMPRESSOR (W)	415
COMPRESSOR (HP)	1/3
AMPS	8.9

