



# REFRIGERATION

## 35-INCH COUNTERTOP REFRIGERATED DISPLAY

Item: 44630 Model: RS-CN-0160-4

**ATTRACTIVELY DESIGNED  
TO BOOST IMPULSE SALES**

*Omcans 35-inch Countertop Refrigerated Display Case helps to boost impulse sales of your most popular food anytime! This refrigerated display case has interior LED lights on top for better product visibility. Boasting a powerful 330 Watts Input Power, it also features ventilated cooling system and automatic defrost.*



**PRODUCT  
FEATURES**

- Brilliant internal LED lighting on top
- Digital temperature controller and display
- Adjustable chrome plated shelves
- 4 sides are double glass
- Front curved glass
- Ventilated cooling system
- Automatic defrost
- Air duct outside the glass to remove water condensation



**WARRANTY**  
PARTS AND LABOR

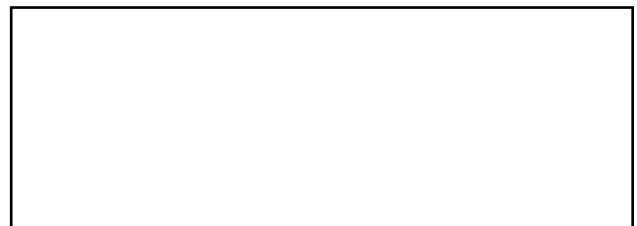

Authorized Dealer

# REFRIGERATION

35-INCH COUNTERTOP REFRIGERATED DISPLAY CASE



## TECHNICAL SPECIFICATIONS

ITEM NUMBER	44630
MODEL	RS-CN-0160-4
CAPACITY (L / CU. FT.)	160 L / 5.65 Cu. Ft
INPUT POWER	0.33 kW
REFRIGERANT	R290
TEMPERATURE RANGE	0° - 12°C / 32° - 53.5°F
ELECTRICAL	110V / 60Hz / 1Ph
SHELF DIMENSIONS	(1) 32" x 13" / 813 x 335 mm, (1) 32" x 13" / 813 x 367 mm
SHELF LOAD CAPACITY (ea.)	33lbs. / 15 kg.
DIMENSIONS (WDH)	34" x 22" x 27" / 874 x 570 x 686mm
GROSS DIMENSIONS	30" x 25" x 30" / 880 x 560 x 686 mm
WEIGHT	145.5 lbs. / 66 kgs.
GROSS WEIGHT	153 lbs / 69.5 kg

## TECHNICAL DRAWINGS WITH DETAILED DIMENSIONS

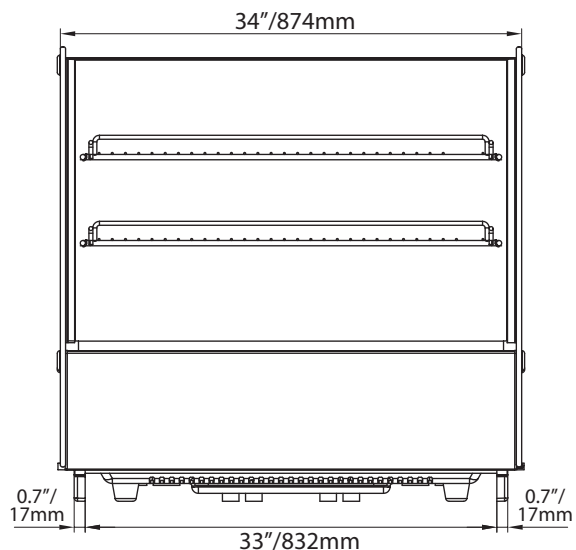
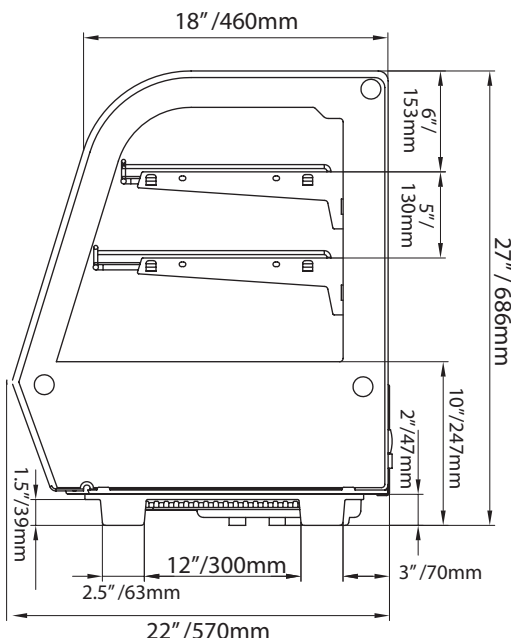

## OMCAN INC.

Telephone: 1-800-465-0234

Fax: (905) 607-0234

E-mail: [sales@omcan.com](mailto:sales@omcan.com)

Website: [www.omcan.com](http://www.omcan.com)



Follow us to keep up to date  
with the latest news and offers



2019.E.O.E