

Mega-Top Prep Tables



Stainless Steel is ideal for your kitchen environment for many reasons which include sanitation, hygiene and is the workhorse for your Restaurant. Asber APTS series Prep Tables features a **stainless-steel exterior front and sides** with an galvanized back. **Complete stainless-steel interior** for the most rugged construction while, easiest to clean with coved corner floors to meet **NSF standards**. Always one step above to ensure the highest standard in safety and sanitation for your establishment.

Insulation in any Refrigerator is one of the most important factors for thermal efficiency. Asber only uses the **world's leader Ecomate (GWP) (ODP) insulation, 2" thick** for the highest R value efficiency for your environments.

Our innovative air flow underneath the pans versus on top helps maintain products at their most optimal temperatures without drying the products. In addition, we have incorporated a bottom panel underneath the pans to prevent food spillage

and force air into the lower compartment for complete air circulation throughout your unit.

With innovative and eco-friendly technology, Asber utilizes **R-290 Hydrocarbon** designed to meet DOE's Energy Conservation standards with very low contribution to global warming (ODP-0) (GWP-3).

Additional features to include:

- Hermetic compressors with epoxy coated evaporator.
- Automatic evaporator: Paper fins not utilized in the evaporation process.
- Standard with 1/6 size and 1/9th size pans, 4" deep.
- Full length removable white Nylamid NSF, 10" cutting board.
- Refrigerators with electromechanical controller.
- Temperature: Refrigerators 32°F to 41°F based on an external environment of 90°F and 65% RH.
- Standard with 4" castors, front with brakes.
- Meets the NSF-7 standard for food safety.



APTM-27-12



APTM-60-24



APTM-72-18

OPTIONS & ACCESORIES

- Additional 2nd year warranty.
- 2.5" castors.
- Voltage: 220V. - 1 - 50Hz.
- Additional epoxy coated shelves.
- 6" adjustable stainless-steel legs.



| MODEL | DOORS | SHELVES | PANS | CAPACITY (Cu. Ft.) | AMPS | HP | VOLTS | DIMENSIONS | | | SHIPPING WEIGHT (lbs) |
|------------|-------|---------|--------------------|--------------------|------|------|--------|------------|-------|---------------------|-----------------------|
| | | | | | | | | Width | Depth | Height ¹ | |
| APTM-27-12 | 1 | 1 | (9) 1/6 (3) 1/9 | 6.1 | 1.5 | 1/10 | 115/60 | 27" | 37" | 47" | 200 |
| APTM-48-18 | 2 | 2 | 18 | 11.8 | 2.5 | 1/3 | 115/60 | 48" | 37" | 47" | 315 |
| APTM-60-24 | 2 | 2 | 24 | 15.0 | 2.5 | 1/3 | 115/60 | 60" | 37" | 47" | 365 |
| APTM-72-30 | 3 | 3 | 30 | 18.2 | 2.5 | 1/3 | 115/60 | 72" | 37" | 47" | 410 |

1. Height with the lid closed (includes 4" diameter castors, 5" overall). 2. Depth includes 10" cutting board; does not include 1" for rear bumper. 3. Specifications are subject to change without prior notice.

Mega-Top Prep Tables



APTM-27-12 FRONT

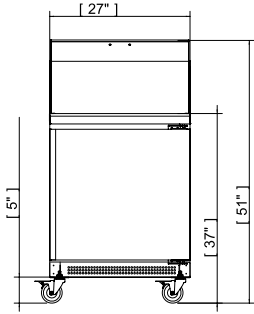

APTM-48-18 FRONT

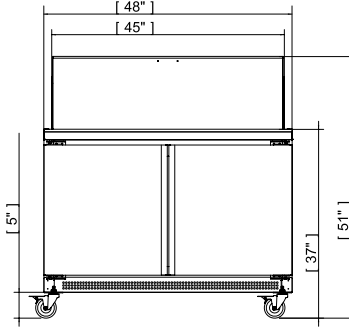

APTM-60-24 FRONT

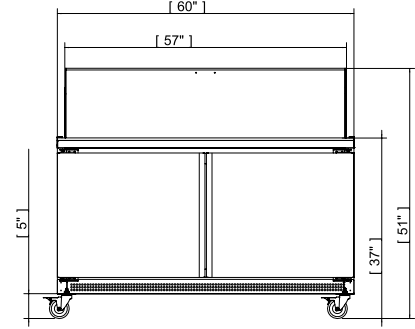

APTM-72-30 FRONT

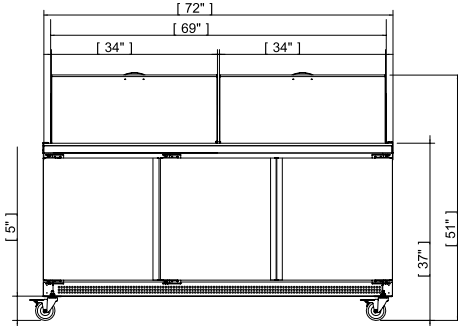

COMMON SIDE VIEW

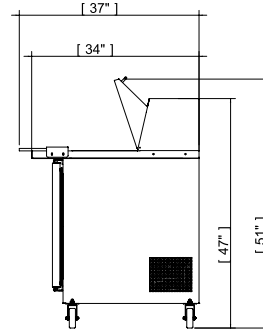

COMMON TOP VIEW

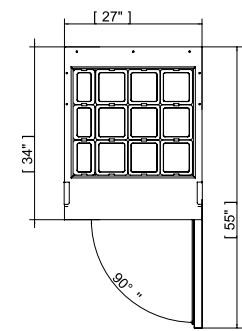

NOTE: Height with lid closed, includes 4" diameter castors (5" overall).

| ELECTRICAL DATA | 27" | 48" | 60" | 72" |
|----------------------------------|---------------|---------------|---------------|----------------------------|
| Voltage | 115/60 | | | |
| Plug Type | Nema 5-15P | | | |
| Full Amp. Loads | 1.5 | 1/10 | | |
| Compressor HP | 2.5 | 1/3 | | |
| Cord Length (ft) | 10 | | | |
| Refrigerant | R-290 | | | |
| DIMENSIONAL DATA | | | | |
| # of Doors | 1 | 2 | 3 | |
| Capacity (cu. ft.) | 5.5 | 10.2 | 13.2 | 16.1 |
| Ext. Width Overall | 27" | 48" | 60" | 72" |
| Ext. Depth Overall ¹ | 37" | | | |
| Ext. Height Overall ² | 47" | | | |
| # of Pans | 12 | 18 | 24 | 30 |
| # of Shelves - Std. | 1 | 2 | | 3 |
| Shelf Size (L x D) | 14 3/4" x 22" | 15" x 20 7/8" | 15" x 26 7/8" | 14 3/4" x 22" 15" x 22" |
| Shipping Weight (lbs.) | 200 | 315 | 365 | 410 |

Standard Features

- Stainless steel Interior and Exterior (except rear).
- 2" Ecomate CFC Free foam in place insulation.
- Standard with 1/6 size and 1/9th size pans, 4" deep.
- Full length removable white Nylamid NSF 10" cutting board.
- Self-contained Refrigeration with epoxy coated evaporator.
- One-piece magnetic door gasket, removable without tools.

Options & Accesories Warranty

- Additional 2nd year warranty.
- 2.5" castors.
- Voltage: 220V. - 1 - 50Hz.
- Additional epoxy coated shelves.
- 6" adjustable stainless-steel legs.

- 1-year parts & labor.
 - 5-year compressor.
- *RESIDENTIAL APPLICATIONS: Asber assumes no liability for parts or labor coverage for component failure, factory defect or any other damages for units installed in non-commercial foodservice or residential applications.

1. Depth includes 10" cutting board; does not include 1" for rear bumper.
2. Height with the lid closed (includes 5" diameter castors, 6" overall).