

# UPRIGHT REACH-IN PASS-THRU REFRIGERATOR GLASS FRONT/SOLID REAR TOP MOUNTED CONDENSING UNIT

Project Name: \_\_\_\_\_

Project Location: \_\_\_\_\_

Model #: \_\_\_\_\_ Quantity: \_\_\_\_\_

Available Warehouse: \_\_\_\_\_

**ES Series**

**Model: ESPT-2G-2S**



### Refrigeration System

- Top mounted, self-contained and fully detachable Blizzard R290 condensing unit uses environmentally friendly, EPA-compliant R290 refrigerant with zero (0) Ozone Depletion Potential (ODP) and three (3) Global Warming Potential (GWP). Blizzard R290 is easily replaceable and requires no on-site brazing.
- Electronically commutated (ECM) fan motors achieve rapid cooling with less energy consumption.
- Full-length air duct system and airflow guard ensure optimal circulation of cold air.
- Time-initiated and temperature-terminated auto defrost cycle for seamless operation.
- Large capacity, corrosion-resistant condenser and evaporator coils.
- Self-maintaining, energy-efficient condensate drain pan requires no external drains or electric heaters.
- High performance, auto-reverse condenser fan motor supports compressor ventilation and condenser coil cleaning. Refer to owner's manual for full maintenance instructions.
- Pressure relief devices allow smooth access to cabinet interior when reopening doors.
- Pre-wired and ready to plug, 115V/60Hz/1Ph, NEMA 5-15P.

### Cabinet Construction

- Pass Thru design allows seamless access from both front and back entry points.
- Heavy duty stainless steel interior / exterior with rounded corners for a hazard-free workspace.
- Galvanized steel top and bottom.
- 2.5" thick high density polyurethane insulation.
- Four 5" swivel casters with locks on front set.

### Lighting

- Energy efficient silicone coated and shatter-proof LED lighting provides bright, high color illumination with low heat output.

### Doors

- Front glass door has low emissivity double glass panes that reflect UV rays for efficient cooling. Rear solid door has stainless steel exterior/interior.
- 2.5" thick high density polyurethane insulation.
- Frame heaters prevent exterior moisture build up.
- Self-closing with adjustable torsion system for a positive seal.
- Snap-in magnetic door gasket make cleaning and replacement an easy process.
- High strength, recessed door handles.
- Pre-installed door locks keep your items safe from theft.
- Field reversible.

### Shelving

- Three epoxy coated, steel wire shelves per section.
- Height adjustable stainless steel clips.

### Temperature Control

- Multi-function digital controller with easy to read LED display.
- Factory preset temperature, 35°F. Temperature setting range from 33°F to 54°F.
- Audible overheat protection alarm for compressor and condenser coil.

### Options

- Additional shelving.
- 3" swivel casters with locks.
- 3.5" – 6" height-adjustable and interchangeable legs.
- Left hinged door.

**Operating temperature range is 33°F ~ 54°F**



**5 YEAR Compressor  
3 YEAR Parts & Labor**



Please visit our website for updated Energy Efficiency information

Ref/ Frz/Dual	Doors	Capacity Cu. Ft.	Shelves	Refrigerant	HP	Power V-Hz-Ph	Amps	Crated Weight	Exterior Dimensions		
									L	D	H*
REF	4	48	6	R-290	1/3+	115-60-1	5.64	516 lbs (234kg)	49.625" (1260mm)	33.71" (856mm)	74.25" (1886mm)

(†)Based on evaporating temperature of 23°F (-5°C) & condensing temperature of 131°F (55°C). (►) Product capacity is calculated based on standard industry figures. (✳) Reference plan view for clarification on caster/unit height. If dimensions and capacity are critical, please contact Everest Refrigeration. Blizzard R290 replacement is at the sole discretion of Everest Refrigeration. Specifications subject to change without notice.

# UPRIGHT REACH-IN PASS-THRU REFRIGERATOR GLASS FRONT/SOLID REAR TOP MOUNTED CONDENSING UNIT

## ES Series Model: ESPT-2G-2S

### DIMENSIONAL DATA

External Dimensions	L	49.625" (1260mm)
	D	33.71" (856mm)
	H*	74.25" (1886mm)
Crated Weight		516 lbs. (234kg)
Doors/Drawers/Lids		4
Max Weight Support (LBS)		-

### STORAGE DATA

Net Capacity Cu. Ft. ▶	48
Shelves	6
Barrels	-
20 oz. Bottles	-
12 oz. Bottles	-
12 oz. Cans	-
8" Mugs	-
# of Pans (Top)	-
# of Pans (Drawer)	-
Dividers	-
Trays	-

### ELECTRICAL DATA

Voltage	115-60-1
Full Load Amperage	5.64A
Feed Wires with Ground	3
Cord Length	9ft
NEMA Plug Type	ⓘ NEMA 5-15P

### REFRIGERATION DATA

Compressor Mounting	Top
Refrigerant	R-290
Compressor HP	1/3+
BTU/HR †	1926

### KEY

D	Door	R	Refrigerator
L	Lid	REF	Refrigerator
H	Half Door	F	Freezer
FD	Full Door	FRZ	Freezer
SD	Solid Door	DUAL	REF/FRZ Combo
GD	Glass Door	DR	Drawer

	Elevation	Right	Plan	3D	Back

### PLAN VIEW

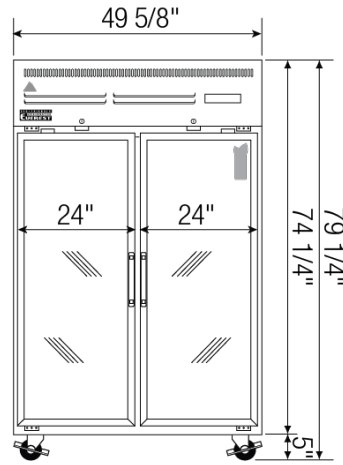

FRONT

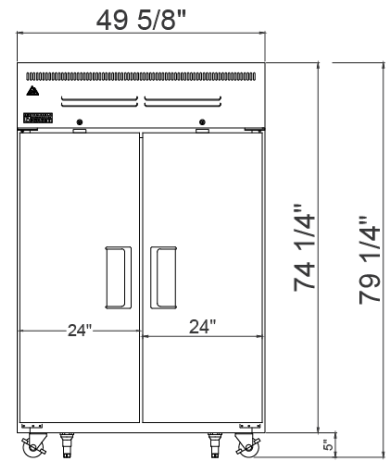

REAR

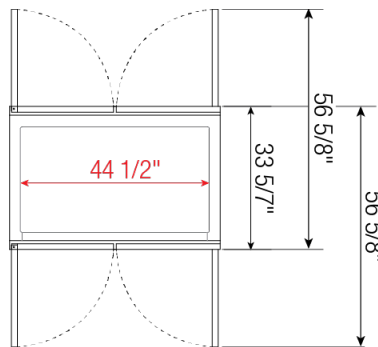

TOP

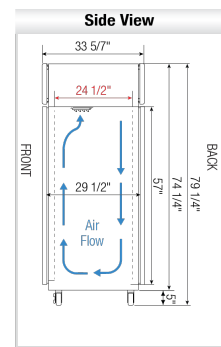

SIDE

### ACCESSORIES & OPTIONS

Part Number	Description
<b>Additional Shelving</b>	Contact Everest Refrigeration for more information.
<b>AJL03-00</b>	Interchangeable Leg for Caster
<b>CASA3-01</b>	3" Overall Height Caster Assembly - (2) Front (2) Rear

(†) Based on evaporating temperature of 23°F (-5°C) & condensing temperature of 131°F (55°C). (▶) Product capacity is calculated based on standard industry figures. (✖) Reference plan view for clarification on caster/unit height. If dimensions and capacity are critical, please contact Everest Refrigeration. Blizard R290 replacement is at the sole discretion of Everest Refrigeration. Specifications subject to change without notice.