



HERCULES

Spiral mixers

- HERCULES 20B
- HERCULES 30
- HERCULES 30TA (Lift head + bowl removal)
- HERCULES 40TA (Lift head + bowl removal)
- HERCULES 50TA (Lift head + bowl removal) - pictured

HERCULES 30



HERCULES 50 TA



Design and Sanitary:

- Ideal for bakeries, pizzerias, pastry shops, commissaries. Versatile from low to high absorption doughs
- Large thickness C 40 steel construction painted with scratch-resistant powder coating
- Heavy-duty stainless steel bowl with reinforced edge
- Heavy-duty stainless steel spiral dough hook and kneading bar
- Hercules 30TA, 40TA and 50TA: Lift head and bowl removal for an easy and thorough sanitation

- Motor:** High-efficiency, high torque motor, sturdy oil-bath gearbox and reinforced chain drive.
- Controls:** Low-voltage IP 67 waterproof no-volt release controls. Thermal overload protection circuit breaker
- Safety:** Interlocked lid with opening to add ingredients during operation
- Capacity:** See Dough capacity chart on reverse





Certified to UL 763 and NSF 08
 Certified to CSA Standard C22.2



Interlocked lid with opening to add ingredients during operation



Lift head



Heavy-duty stainless steel spiral dough hook and kneading bar

DOUGH CAPACITY CHART BY ABSORPTION RATE (AR)

	HERCULES 20B	HERCULES 30	HERCULES 30TA	HERCULES 40 TA	HERCULES 50TA
	LBS (KG)	LBS (KG)	LBS (KG)	LBS (KG)	LBS (KG)
60% AR THICK PIZZA	37 ½ (17)	55 (25)	55 (25)	77 (35)	97 (44)
50% AR MEDIUM PIZZA	33 (15)	49 (22)	49 (22)	69 (31 ½)	87 (40)
40% AR THIN PIZZA	19 (9)	28 (13)	28 (13)	39 (18)	49 (22)
65% AR RAISED DONUT	37 ½ (17)	55 (25)	55 (25)	77 (35)	97 (44)
60% AR BREAD/ROLL	37 ½ (17)	55 (25)	55 (25)	77 (35)	97 (44)
55% AR HEAVY BREAD, BAGEL, PRETZEL	34 ½ (15 ½)	51 (23)	51 (23)	72 (33)	90 (41)

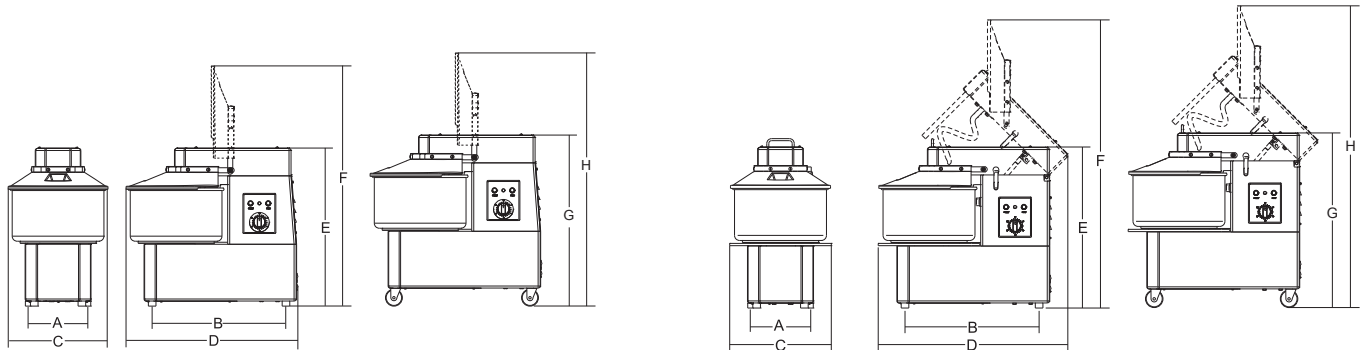

	Power	Power source	Spiral Revolutions	Bowl capacity	Dough capacity	Bowl dimensions (diameter x height)	A	B	C	D	E	F	G	H	Net weight	Shipping	Gross weight
	watt/Hp		r.p.m.	qt	lbs.	inch.	inch.	inch.	inch.	inch.	inch.	inch.	inch.	inch.	lbs.	inch.	lbs.
Hercules 20B	750/1	110V/60Hz	10 - 85	22	37 ^{1/2}	14 1/8 x 8 1/4	9 1/16"	20 ^{55/64} "	15 ^{23/64} "	26 ^{49/64} "	24 ^{39/64} "	37 ^{13/32} "	27 ^{3/4} "	40 ^{35/64} "	145	21" x 33" x 41"	170
Hercules 30	1100/1,5	220V/60Hz	10 - 85	34	55	15 3/4 x 10 1/4	10 ^{5/8} "	23 ^{15/64} "	17 ^{21/64} "	29 ^{9/64} "	27 ^{9/16} "	41 ^{11/32} "	30 ^{45/64} "	44 ^{31/64} "	209	21" x 33" x 41"	230
Hercules 30 TA	1100/1,5	220V/60Hz	10 - 85	34	55	15 3/4 x 10 1/4	10 ^{5/8} "	23 ^{15/64} "	17 ^{21/64} "	32 ^{13/32} "	27 ^{61/64} "	49 ^{39/64} "	31 ^{7/64} "	52 ^{3/4} "	240	21" x 33" x 41"	260
Hercules 40 TA	1500/2	220V/60Hz	10 - 85	43	77	17 3/4 x 10 1/4	12 ^{13/64} "	25 ^{53/64} "	19 ^{19/64} "	35 ^{53/64} "	29 ^{9/64} "	53 ^{35/64} "	32 ^{9/32} "	56 ^{11/16} "	275	32" x 48" x 48"	390
Hercules 50 TA	1500/2	220V/60Hz	10 - 85	55	97	19 3/8 x 10 3/8	12 ^{13/64} "	26 ^{49/64} "	21 ^{17/64} "	38 ^{3/16} "	31 ^{19/64} "	55 ^{45/64} "	34 ^{29/64} "	58 ^{55/64} "	400	32" x 48" x 48"	430

