

## MODELS

KFM-SC-(40, 50, 60, 80, 100, 120)-S

KFM-SC-(40, 50, 60, 80, 100, 120)-R

**CURVED GLASS SEAFOOD CASE  
DESIGNED FOR FRESH FISH**

CASE HOLDS 33°F TO 40°F • LOW VELOCITY FORCED AIR REFRIGERATION MAINTAINS HIGH HUMIDITY  
TEMPERED SIDE GLASS AND REAR SLIDING DOORS • CASES CAN BE MULTIPLEXED  
CAN BE USED WITH OPTIONAL ICE PANS • CASES REQUIRE FLOOR DRAINS



AUTODESK®  
REVIT®

SELF CONTAINED	Model	O.A. Length (inches)	Volume FT <sup>3</sup>	Electrical 115 Volts				NEMA 115 V Plug	Weight lbs		Crate Size (inches)			
				Front	Compressor		LIGHTS Fans HTRS		Total Amps	No Crate	With Crate	L"	W"	H"
					H.P	F.L.A								
	KFM-SC-40-S	40.4	12.35	3/8	8.4	0.95	9.35	5-15P	333	494	48	44	42	
	KFM-SC-50-S	52.2	16.27	1/2	9.6	0.96	10.56	5-15P	377	560	59	44	42	
	KFM-SC-60-S	60	18.88	1/2	9.6	1.08	10.66	5-15P	427	626	67	44	42	
	KFM-SC-80-S	77.5	24.70	5/8	8.9	1.68	10.58	5-15P	531	794	85	44	42	
	KFM-SC-100-S	101.4	32.54	3/4	16	1.81	17.81	5-15P	658	937	109	44	42	
	KFM-SC-120-S	117	37.76	3/4	16	2.06	18.06	--	785	1160	124	44	42	

OPTIONAL ICE / FISH	Kit No	For Model
	KT025A	KFM-SC/SF/SO-40-S/R
	KT025B	KFM-SC/SF/SO-50-S/R
	KT025C	KFM-SC/SF/SO-60-S/R
	KT025D	KFM-SC/SF/SO-80-S/R
	KT025E	KFM-SC/SF/SO-100-S/R
	KT025F	KFM-SC/SF/SO-120-S/R

REMOTE	Model	O.A. Length (inches)	115 Volts Total Amps	B.T.U	Weight lbs	
					No Crate	With Crate
					KFM-SC-40-R	40.4
KFM-SC-50-R	52.2	0.51	3015	322	505	
KFM-SC-60-R	60	0.63	3159	373	571	
KFM-SC-80-R	77.5	0.78	4345	498	761	
KFM-SC-100-R	101.2	0.91	5112	604	882	
KFM-SC-120-R	117	1.16	5472	721	1093	

#### STANDARD FEATURES

- Coated evaporator coil
- Stainless steel frame
- Stainless steel interior
- Stainless steel rear work bench
- Silver colored PVC coated steel front panel
- CFC free injected foam insulation
- Black steel kick plate
- Foamed polystyrene black end panels
- Tempered tilt forward front glass
- Removable rear tempered glass sliding door
- LED lighting in canopy
- Temperature and defrost regulated by a digital controller
- Slide out condensing unit on self-contained units
- Anti condensing system for front glass
- Digital thermometer
- Levelling feet

#### OPTIONAL FEATURES

- Ice/fish pan kit. See table above
- Stainless steel exterior
- Other colors available
- Joining Kit
- Partition
- Scale stand with receptable
- Cutting Board
- Knife Support
- Casters add 4-3/8" to height
- Stainless steel legs are adjustable from 5-1/8" to 7-5/8"

#### WARRANTY

One year parts and labor with an additional four years on the compressor (part only)

 Tel: 786.600.4687 / Toll Free: 844.218.8477  
Fax: 786.661.4100

 Tel: 514.737.9701 / Toll Free: 888.275.4538  
Fax: 514.342.3854 / toll free: 877.453.8832

06/2017 sales@mvpgroupcorp.com / mvpgroupcorp.com

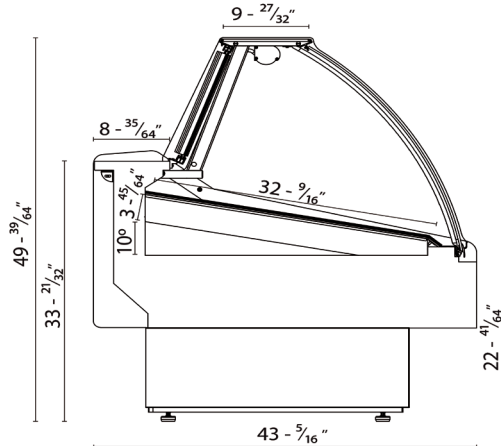

Standard Mounting



Levelling Feet

Optional Mounting



Adjustable Legs



Casters

#### NOTE

These cases are engineered to operate in locations not exceeding 75°F and 55% R.H. These cases are designed to operate using R404a refrigerant. Alternate refrigerants available by special order. O.A. length includes (2) ends at 1-7/8" each. Ventilation grills at front and back cannot be blocked. B.T.U's are calculated at 14°F (evaporator) and 90°F (ambient). Remote cases are provided with an expansion valve and a liquid solenoid for pump down cycle. Remote cases must be hard wired-no plugs.



Hydra - Kool is a registered trademark of MVP Group Corp.  
SPECIFICATIONS SUBJECT TO CHANGE WITHOUT NOTICE