

Deli Case

NJ-4 | NJ-5 | NJ-6



Features

- Stainless steel exterior, SS304 and coated metal for interior
- Refrigeration system is optimized to function between 35~ 41 °F
- Exterior tempered glass finish
- With caster and adjustable legs
- Curved glass front with heater
- Two adjustable shelves as standard
- Gravity coil refrigeration system provides high humidity environment for exceptional preservation
- Sliding out condensing unit
- LED lights on both sides and the top
- High quality digital temperature controller
- Double glazed safety glasses with heater
- Automatic defrost system for front glass and rear door frame
- R290 refrigerant, ozone friendly
- ETL approved (conforms to UL-471&NSF-7)
- DOE 2017, Energy efficient compliant PRODUCT



Model	Doors	Capacity (cu.ft)	Shelves	Cabinet Dimesions (Inches)			HP	Voltage	Amps	Cord Length (ft.)	Net Weight (lbs.)
				W	D	H					
NJ-4	2	18	1	47.3"	32.5"	47"	1/3	110V/60Hz	5.00	6	496
NJ-5	2	21.5	1	59"	32.5"	48.2"	3/5	110V/60Hz	5.80	6	573
NJ-6	2	26.4	1	70.9"	32.5"	47"	3/4	110V/60Hz	6.40	6	650



Project Name:	
Location:	
Item:	Qty:
Model:	

Deli Case
 NJ-4 | NJ-5 | NJ-6

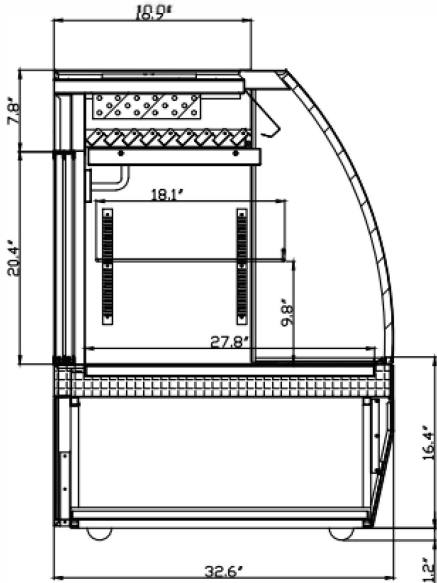
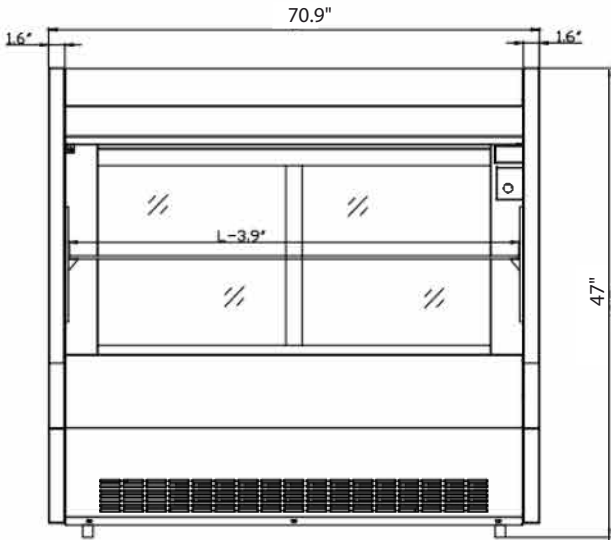
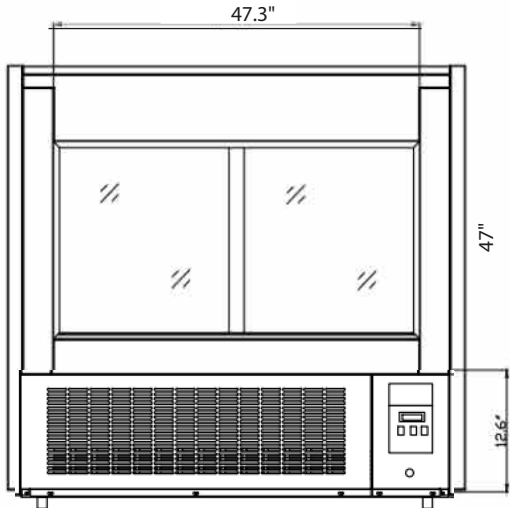

DOE 2017
 Energy Efficiency
 Compliant

Warranty: 12 months parts and labor.
 Additional 48 months on compressor (part only)