



**REFRIGERATED REAR STORAGE**

## MODELS

KPM-OF-(60, 80, 100)-S  
KPM-OF-(60, 80, 100)-R

**OPEN FRONT DELI CASE  
DESIGNED FOR DELI PRODUCTS  
AND PACKAGED MEAT**

Case holds 33°F to 40°F • Forced air refrigeration • Tempered front and side glass • Refrigerated rear storage • Cases can be multiplexed



Intertek

Intertek

SELF CONTAINED	Model	O.A. Length Inches	Volume FT <sup>3</sup>		Electrical - 115 volts						NEMA 115V Plug	Weight LBS.		Crate Size		
			Front	Back	Compressor			Lights Fans HTRS	Evap Pan	Total Amps		No Crate	With Crate	W L H		
					H.P.	F.L.A.	L.R.A.							"L"	"W"	"H"
	KPM-OF-60-S	60	9.29	5.33	1/2	9.6	49	0.83	3.3	14.08	5-15P	407	630	67	44	42
	KPM-OF-80-S	77-1/2	12.15	8.76	1/2	9.6	49	0.96	3.3	14.08	5-15P	495	758	85	44	42
	KPM-OF-100-S	101-1/8	16.00	13.41	5/8	8.9	47	1.31	3.3	13.51	5-15P	620	939	108	44	42

REMOTE	Model	O.A. Length Inches	No. of Rear Doors	115 Volts Total Amps	B.T.U.	Weight LBS.	
						No Crate	With Crate
	KPM-OF-60-R	60	1	0.70	2959	352	575
	KPM-OF-80-R	77-1/2	2	0.7	3253	440	703
	KPM-OF-100-R	101-1/8	3	1.05	4372	565	884

## STANDARD FEATURES



- Insulation-CFC free injected foam
- Interior-PVC coated steel gray
- Exterior-PVC coated steel silver
- Silver colored PVC coated steel front panel with black steel kick plate
- Foamed polystyrene black end panels
- Tempered front and side glass
- Temperature and defrost regulated by a digital controller
- Removable condensate evaporative pan for easy cleaning on S/C only
- Slide out condensing unit on S/C only
- Digital thermometer
- Levelling feet

## OPTIONAL FEATURES

- Stainless steel interior
- Stainless steel exterior
- Other colors available
- Joining kit
- Condensate evaporative pan for remote cases
- White epoxy bi-level wire racks (2) or (3) level step sham
- Scale stand with receptacle
- Cutting board
- Knife support
- Casters add 4-3/8" to height
- Stainless steel legs are adjustable from 5-1/8" to 7-5/8"

## WARRANTY

One year parts and labor with an additional four years on the compressor (part only)

 Tel: 786.600.4687 / Toll Free: 844.218.8477  
 Fax: 786.661.4100  
 Tel: 514.737.9701 / Toll Free: 888.275.4538  
 Fax: 514.342.3854 / Toll Free: 877.453.8832

sales@mvpgroupcorp.com / mvpgroupcorp.com

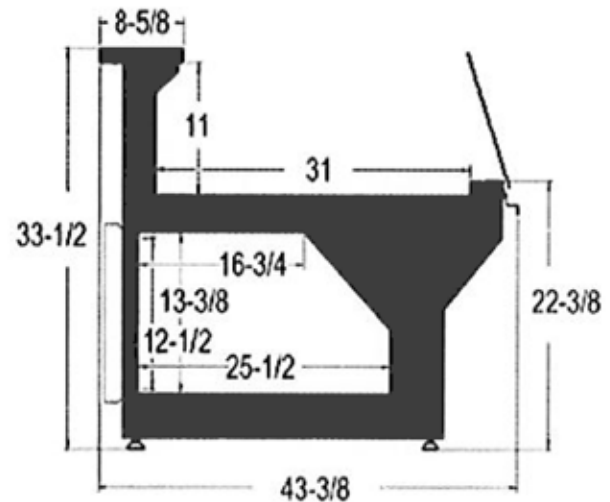

## NOTE

These cases are engineered to operate in locations not exceeding 75°F and 55% R.H. These cases are designed to operate using R404a refrigerant. Alternate refrigerants available by special order. O.A. length includes (2) ends at 1-1/2" each. Ventilation grills at front and back cannot be blocked. B.T.U.'s are calculated at 14°F (evaporator) and 90°F (ambient). Remote cases are provided with an expansion valve and a liquid solenoid for pump down cycle. On remote cases, if no floor drain is provided, a condensate evaporating pan must be ordered and 3.3 amps added to the amp load. Remote cases must be hard wired - no plugs.