



460 Southport Commerce Blvd.
 Spartanburg SC 29306
 Phone: 864-574-6004
 Fax: 864-574-6005
 www.ojedausa.com
 sales@ojedausa.com

Project: _____
 Model #: _____
 Item #: _____ Qty: _____
 Approval: _____

CHEST FREEZER

NCFH-51



ADJUSTABLE THERMOSTAT
 Freezers are equipped with a mechanical thermostat that allows the users to adjust temperature that best fits their products needs. Set from factory at -4°F.

STEEL CONSTRUCTION
 Robust steel construction minimizes the use of plastic materials resulting in an environmentally friendly design.

LID LOCK
 Equipped with a security lock (standard).

FOAMED DOOR
 Solid chest freezer door with a perfect closing seal. The location of the equipment must allow at least a 75° opening angle.

OPERATING TEMPERATURE
 -10°-0°F

CUSTOM GRAPHICS
 Standard color: white

Dimensions			Crated Dimensions			Baskets	HP	Voltage	NEMA config	Amps	Crated Weight		
	W	D	H		W	D	H	1	1/3	120	5-15P	3.5	312 lbs
(in)	49.3	27.1	34.6	(in)	51.3	28	36.3	Net Capacity (cf): 13			Energy Consumption: 1.81 kw-hr/24 hrs		
(mm)	1250	686	878	(mm)	1303	709	920						

*Inches rounded up one decimal place *Specifics may change without notification



OPERATING CONDITIONS

- The unit is best suited for an environment where temperatures remain below 85 F and humidity does not exceed 55%
- Areas with direct sunlight should also be avoided

WARRANTY

- 3 year parts and labor warranty
- 5 year compressor part

CABINET CONSTRUCTION

- High-density, CFC-Free, polyurethane insulation
- Exterior: Galvanized metal cabinet with powder coated painted surface
- Interior: Easy to clean pre-painted steel
- Heavy Duty Casters
- Drain plug for easy cleaning

REFRIGERATION

- Maintenance free condenser
- Adjustable Thermostat
- Easy to reach components for maintenance
- Triple access air flow compressor compartment.

BASKETS

- Removable Wire baskets

BASKETS



HINGE



REMOVEABLE GASKET

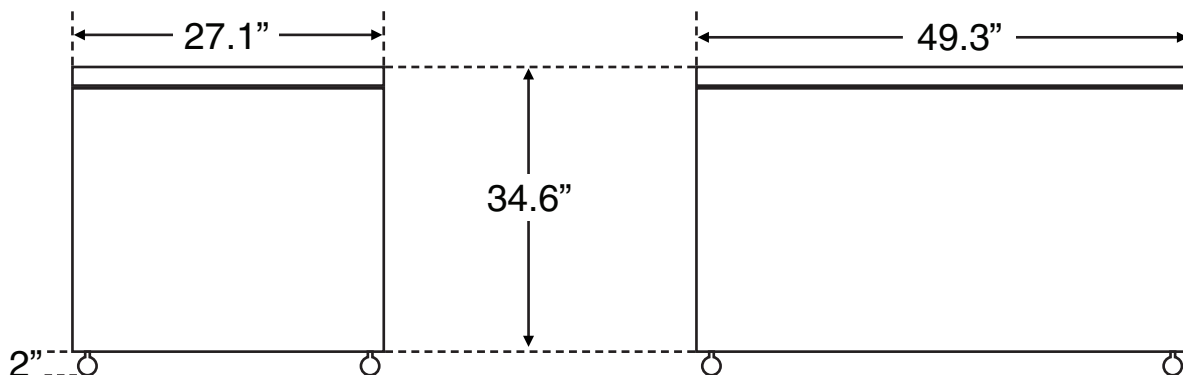

*Specifics may change without notification

