

System Summary

The OSI-10-2C Twin Filter Cartridges provide excellent sediment filtration, chlorine removal and mineral scale control for water-fed equipment such as ice machines.

The cartridges utilize a premium high grade carbon block filter ensuring high flow rates and treatment volumes.

The OSI-10- 2C Cartridges also incorporate the patented HydroBlend™/ScaleStick™ scale control insert providing unparalleled mineral scale prevention and corrosion control for predictable treatment periods.



Benefits

Mineral scale buildup responsible for increased maintenance is reduced

Removes sediment that causes cloudy ice and plugs distribution tubes and float valves

Energy efficiency and machine life are increased while reducing costly service calls

Removes chlorine to improve taste and reduce potential corrosion issues

Features

Bayonet style quick disconnect cartridge makes filter replacement sanitary, quick and easy

Compact design facilitates system placement and installation

HydroBlend™/ScaleStick™ insert provides optimum scale prevention and a consistent feed throughout the life of the cartridge

Installation Summary

Install cartridge into the head by lining up the ears of the filter to the notches of the head

Push upward into the head until it seats, then turn clockwise until the filter stops

Flush system for one minute prior to use.

Operating Tips

Recommended cartridge replacement every 6 months or when water pressure drops below 30 psi.

Application

Ice Machines

Cartridge Specifications

Rated Service Flow (each)

1.65 gpm. (6.24 lpm.)

Rated Capacity (each)

10,000 gal. (Chlorine Removal)

Operating Pressure

30 - 125 psi. (2 - 8.6 bar) non-shock

Operating Temperature

35° - 100°F (2° - 38°C)

Shipping Weight

4 lbs.

Cartridge Dimensions (2)

12.25" x 4" x 4" (HxWxD)

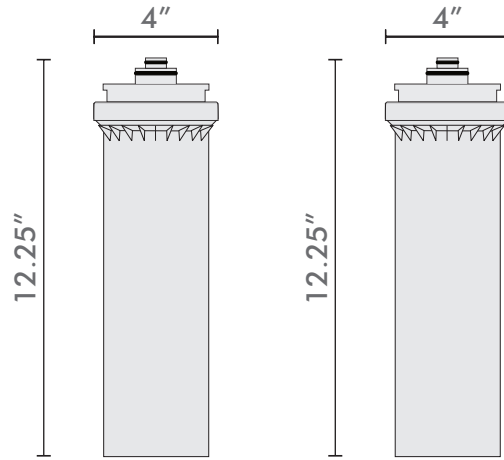

Warranty

OSI-10-1K systems are covered by a limited warranty against defects in material or workmanship for a period of 1 year after the date of purchase.

OSI-10-1C replacement filters are covered by a limited warranty against defects in material or workmanship for a period of 1 year after the date of purchase.

Please call (888) 275-4538 for further warranty information.

Additional Info

Do not use with water that is microbiologically unsafe or unknown quality without adequate disinfection before or after the system

System should be installed in compliance with state and local laws and regulations.