

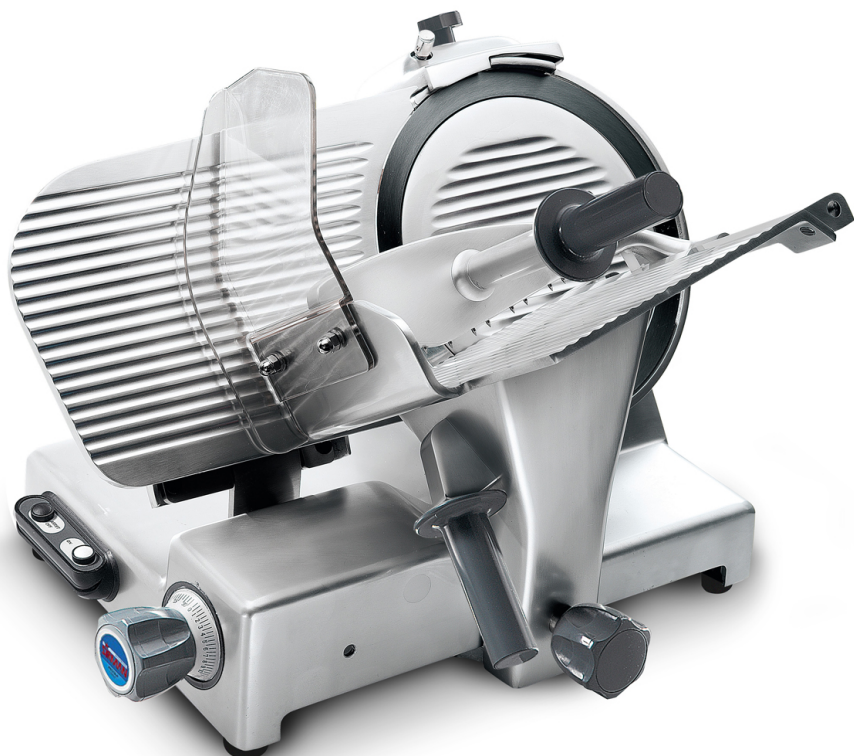

Certified to UL STD. 763 and NSF Std. 08

PALLADIO 300 - 12" PALLADIO 330 ING 13" GEAR DRIVE PALLADIO 350 - 14" Heavy-duty slicers



Palladio Series



- Heavy-duty 1/2 Hp slicers, designed for medium to large operations, perfect for cheese slicing
- Exclusive high-quality, rounded, no edges design, increased blade and machine body gap, easy breakdown for a fast and effective cleaning
- Inner blade cover ensures a perfectly aligned cut. No waste when cutting same product at different times.
- Zero blade exposure due to a permanent blade rim guard and a carriage lockout to prevent exposed blade edge when the carriage and blade guard are removed for cleaning purposes
- Safety hand guard mounted to the carriage
- No voltage release prevents inadvertent reactivation after a power outage
- High-performance gear knife drive on Palladio 330 ING.

Technical:

- The sharpener assembly is made entirely from aluminum, no plastic presence that may break with heavy use.
- The tie rod assembly and all external screws are made of stainless steel for longer life.
- The slide shaft is made of ground, chromed steel for a smoother operation.
- The high-quality bushings and ball bearings are self-lubricating.
- The dial thickness control cam system allows for an always precise cut.

Safety:

- A safety cover is placed under the motor and the electrical components.
- The hopper features an exclusive heavy duty plastic protection to keep operator's hand at a safe distance from the blade while operating the slicer.
- A permanently-mounted knife ring guard covers the non-cutting side of the blade.
- Overcurrent protection

Sanitary:

- Easy to clean aluminum alloy construction does not crack or stain.
- The screws are stainless steel and resist wear and oxidation.
- The carriage and the center plate are quickly removable without tools.
- Exceptionally easy and roomy access to the back of the blade.

Specifications

Operation:	Gravity feed.
Construction:	Polished, anodized aluminum alloy.
Knife:	One piece, chromium plated 100Cr6 forged carbon steel blade.
Sharpener:	Built-in, removable, two stone dual action.
Slice thickness:	Infinitely variable up to 1 ^{3/16} "
Motor, PLL 300-350:	0.55 Hp (410 W), fan-cooled, belt driven.
Motor, PLL 330 ING:	0.55 Hp (410 W), fan-cooled, GEAR DRIVEN.
Electrical:	120V AC, 60Hz, 2.0A (220V, 50Hz available on request).
Plug & Cord:	Attached, flexible, 3 wire SJT 18 AWG, 6'4" long cord.
Controls:	ON/OFF push button switch with indicator light, no-voltage release





The carriage is quickly removable without tools.



Wide gap between blade and body



The carriage is quickly removable without tools.



Inner blade cover avoids product waste

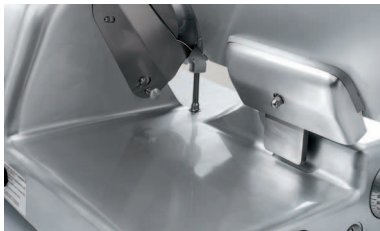

Large receiving tray

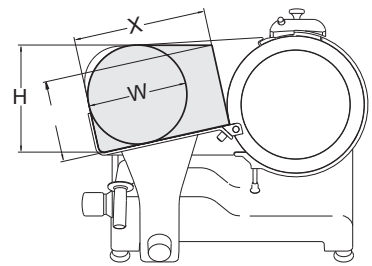
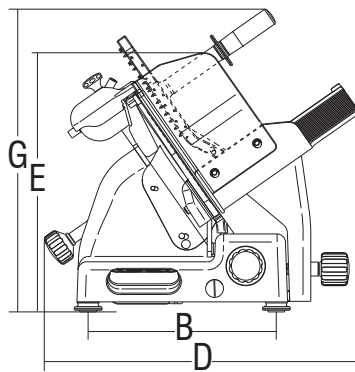
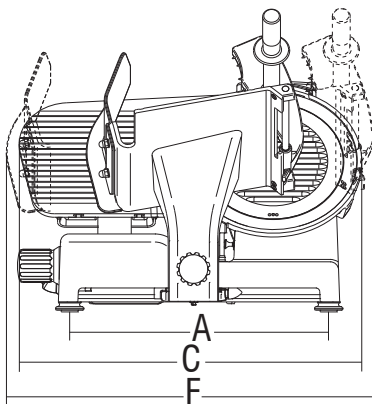

	Ø Blade	Motor	Cut thickness	Blade rpm	Carriage stroke	Carriage	A	B	C	D	E	F	G	X	Y	H	W	Net weight	Shipping Ship on pallet	Gross weight
	mm/inch	watt/Hp	inch.	rpm	inch.	inch.	inch.	inch.	inch.	inch.	inch.	inch.	inch.	inch.	inch.	inch.	inch.	lbs.	inch.	lbs.
Palladio 300	300/12"	410-0.55	1 3/16"	340	12 3/16"	12" x 10 5/8"	18 5/16"	13 3/8"	24 3/16"	21 9/16"	18 5/16"	27 15/16"	21 7/16"	10 5/8"	7 1/2"	9 7/16"	8 11/16"	90	32" x 48" x 26"	135
Palladio 330 ING	330/13"	410-0.55	1 3/16"	315	12 3/16"	12" x 10 5/8"	18 5/16"	13 3/8"	25 3/8"	22 7/16"	17 5/16"	27 15/16"	21 1/16"	10 5/8"	8 1/4"	10 1/4"	9 7/16"	94	32" x 48" x 26"	139
Palladio 350	350/14"	410-0.55	1 3/16"	315	12 3/16"	12" x 10 5/8"	18 5/16"	13 3/8"	26	22 5/8"	17 15/16"	27 15/16"	20 7/8"	10 5/8"	8 7/8"	10 13/16"	9 13/16"	92	32" x 48" x 26"	137