



www.santos.fr

### GRATER #02

For cheese, chocolate, dried fruits, peanuts...



Internationally patented models





**THE GENUINE**

**THE GENUINE GRATER SINCE 1954**

The genuine Santos grater #02 is the ideal appliance for all kinds of cheese, chocolate, peanuts and dried fruits...  
Dedicated to cheese shops, supermarkets, pizzerias, cake shops.  
**Its new design** facilitates cleaning and maintenance.

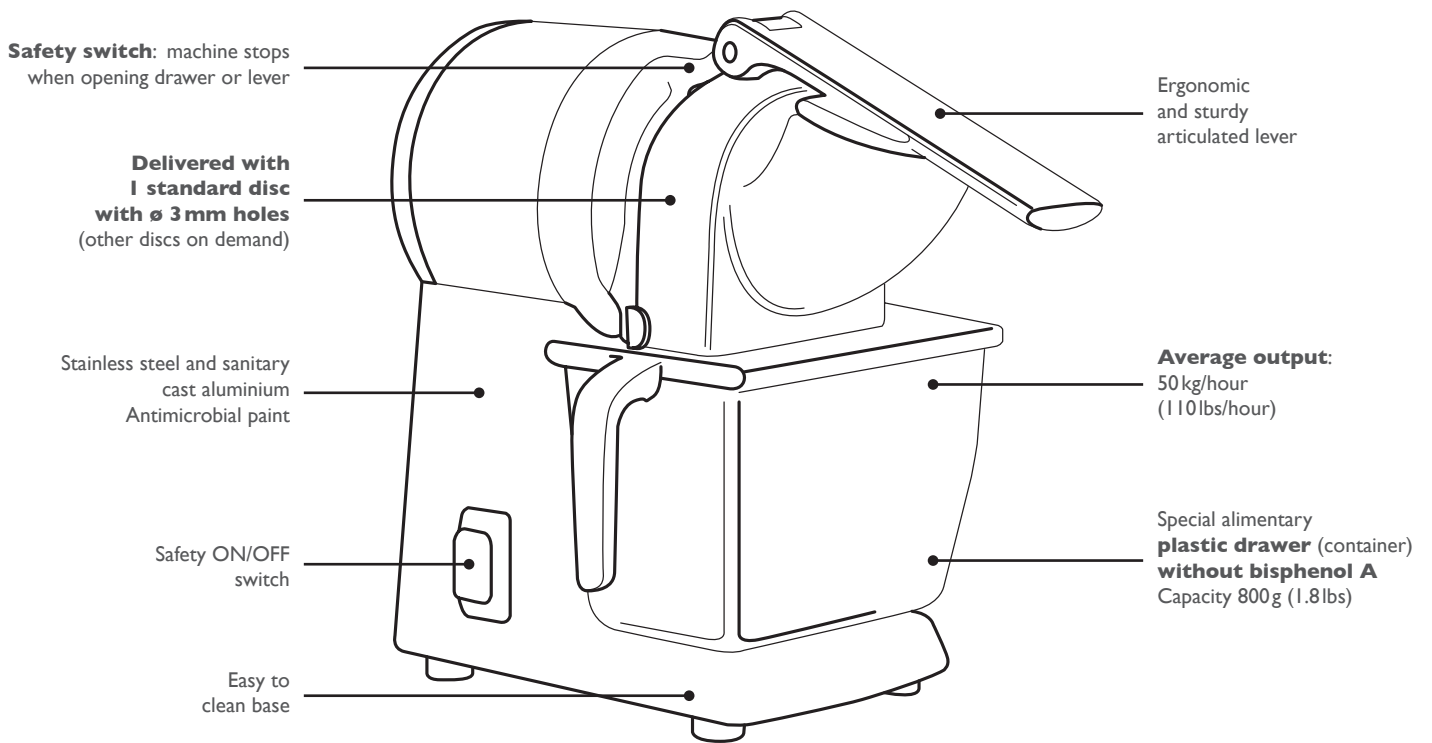

 **Output 50kg/h (110lbs/h)**

**EASY TO CLEAN**

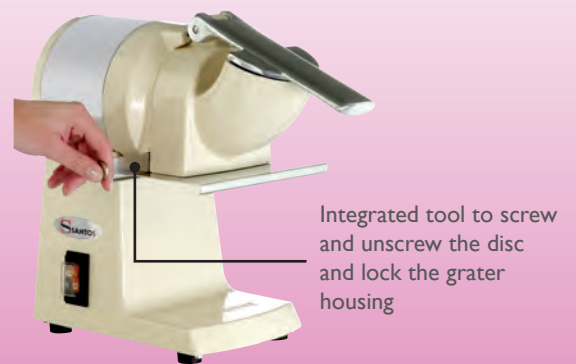

# GRATER #02



A WIDE RANGE OF DISCS TO GRATE EVERYTHING...

www.santos.fr

A unique range of discs to grate all kinds of cheese, dried fruits, chocolate, peanuts...



ø 2mm holes



ø 3mm holes



ø 4mm holes



ø 6mm holes



ø 8mm holes



Specific disc for fondue, mozzarella, chocolate



Specific disc for parmesan, dried fruits, peanuts (very fine)



**Option: The disc for the ice crusher #09 is adaptable to the grater #02.**

## TECHNICAL SPECIFICATIONS



### Motor

Single phase: 100-120V - 50/60 Hz - 650W – CE, UL  
220-240V - 50/60 Hz - 600W – CE

Speed: 1500rpm (50 Hz)  
1800rpm (60 Hz)



### Weight

Net: 14,2kg (31lbs)  
Shipping: 15,2kg (34lbs)

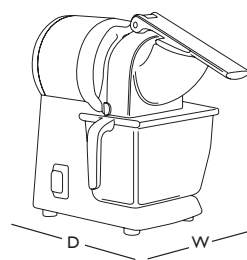

### APPLIANCE

W: 250mm (10")  
D: 420mm (16,5")  
H: 350mm (14")

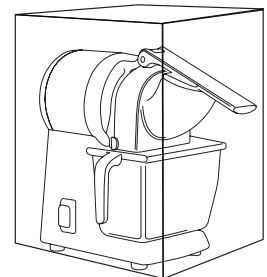

### SHIPPING BOX

W: 295mm (12")  
D: 455mm (18")  
H: 410mm (16")

## SAFETY, STANDARDS, HYGIENE

### In accordance with the following regulations

Machinery directive 2006/42/EC  
Electromagnetic compatibility 2004/108/EC  
«Low voltage» directive 2006/95/EC  
Regulation 1935/2004/EC (contact with food)  
RoHS directive 2002/95/EC

### Harmonized European standards

EN ISO 12100- 1 and 2: 2004-  
EN 60204- 1:2006  
EN 60335-2-64 : 2004 Commercial electric kitchen machines

CE (European standards), UL (USA) and cUL (Canada)

### Thermal safety

Motor protected by internal thermal detector.

### Acoustic safety

Very silent and powerful asynchronous motor.

### Hygiene

All removable parts can be put in a dishwasher or easily cleaned with hot soapy water.

**PRODUCT: 2-YEAR WARRANTY | MOTOR: 5-YEAR WARRANTY**

# THE GENUINE GRATER #02

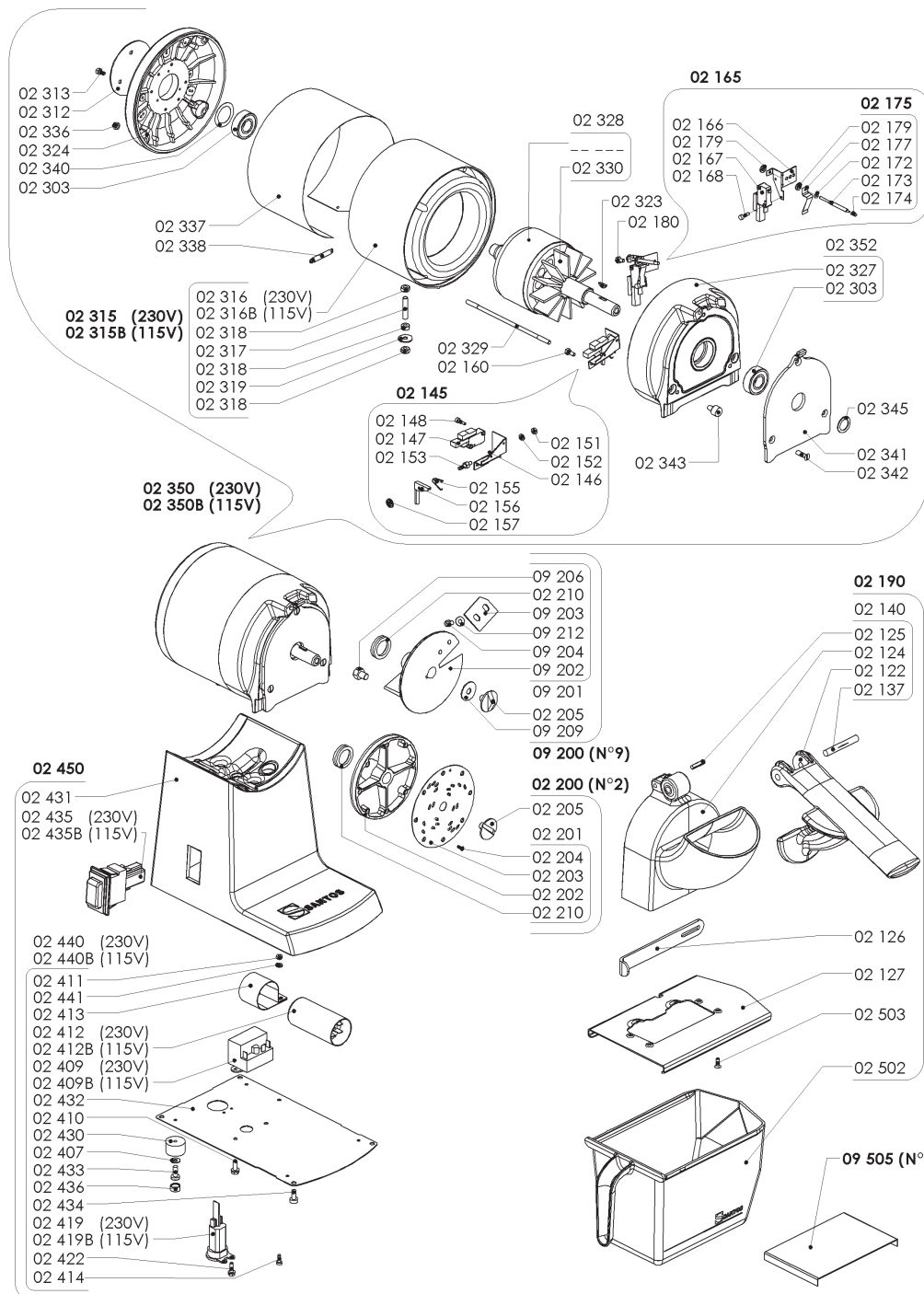

## SANTOS

140-150 Avenue Roger Salengro BP 80 067 – 69511 Vaulx-en-velin Cedex (Lyon) – FRANCE

Tel. +33 4 72 37 35 29 – Fax. +33 4 78 26 58 21 – Website: [www.santos.fr](http://www.santos.fr) – Email: [santos@santos.fr](mailto:santos@santos.fr)

Follow us on #SantosAddict social networks