



www.santos.fr

### CITRUS JUICER #52

For all citrus fruits: limes, lemons, oranges, grapefruits.  
High output model



Internationally patented models





## POWERFUL, EFFICIENT, DURABLE

The citrus juicer #52 is the perfect appliance to squeeze any kind of citrus thanks to the 3 removable squeezers (cones) delivered with the juicer.

This commercial juicer is equipped with powerful and reliable commercial motor.

For use everywhere you need a fresh squeezed citrus juice: juice bars, health food stores, hotels, bars, restaurants, cafeterias, ice cream shops, institutions and hospitals...

**High output:** just cut your citrus half and press. You will extract easily from 20 to 40 liters per hour (5 to 10 gallons).

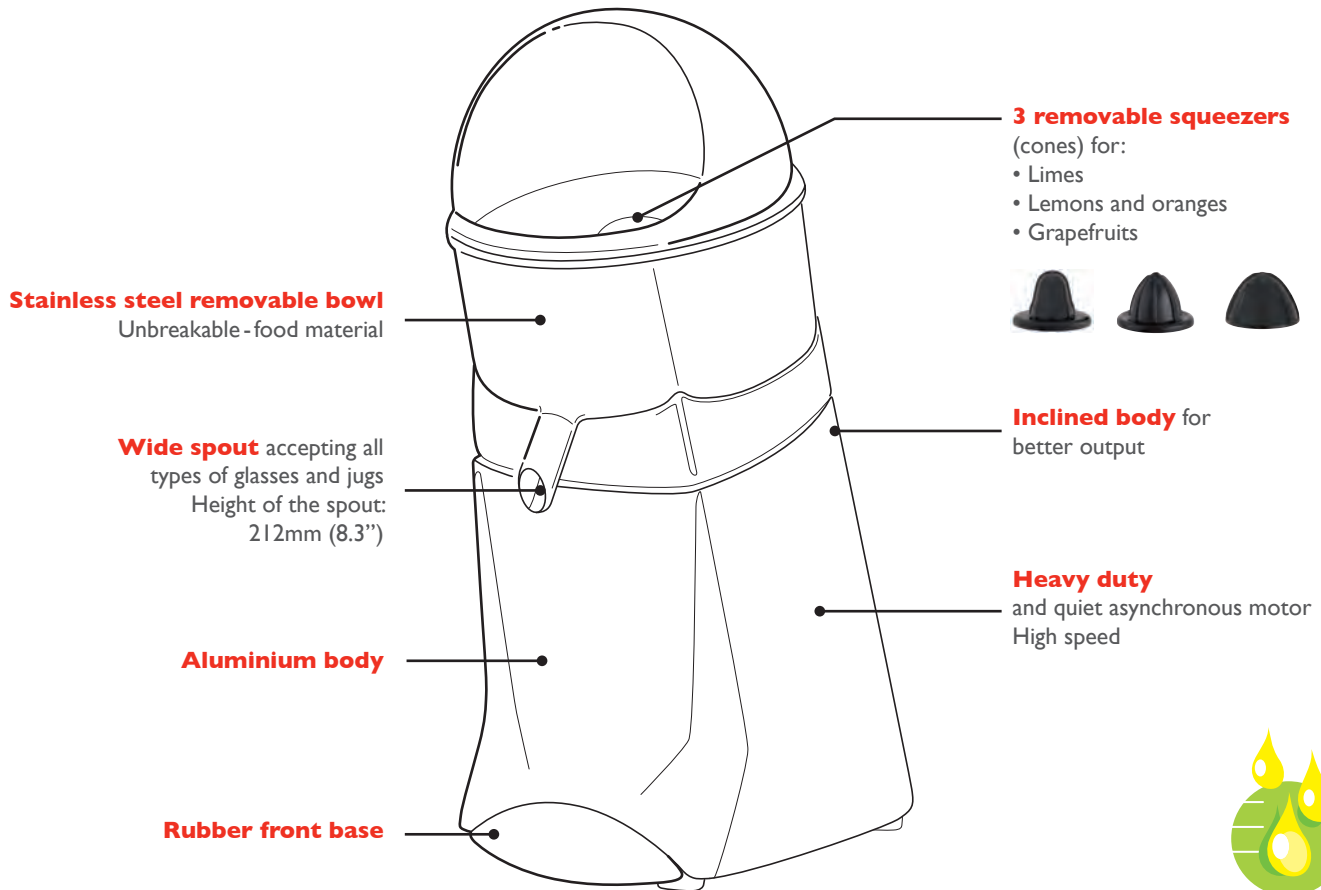

Output up to 40 l/h

## THE COMPLETE RANGE OF THE CITRUS JUICER #52



52C



52G

**CHOOSE**  
YOUR COLOUR!

## CITRUS JUICER #52



**EASY TO USE - EASY TO CLEAN - COMPLETELY SAFE**

www.santos.fr



**The unique juicer that you can clean quickly and easily:** just wash the main different parts of the top. All these parts are easily removable from the base in a simple movement.



### TECHNICAL SPECIFICATIONS



#### Motor

Single phase: 100 - 120V - 50/60 Hz - 260 W - CE, UL, NSF  
220-240V - 50/60Hz - 230W - CE, KC

Speed: | 500 rpm (50 Hz)  
| 800 rpm (60 Hz)



#### Weight

Net: 9,5 Kg (21 lbs)  
Packed: 10,5 Kg (23 lbs)

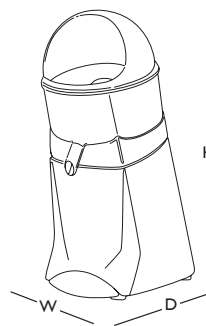

#### APPLIANCE

W: 205mm / 8"  
D: 305mm / 12"  
H: 490mm / 19"

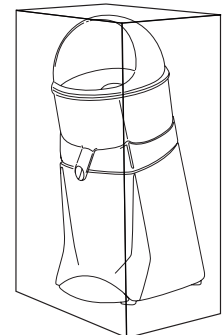

#### SHIPPING BOX

W: 250mm / 9,8"  
D: 300mm / 11,8"  
H: 585mm / 23"

### SAFETY - STANDARDS - HYGIENE

#### In accordance with the following regulations:

Machinery directive 2006/42/EC  
Electromagnetic compatibility 2004/108/EC  
RoHS directive 2002/95/EC  
"Low voltage" Directive 2006/95/EC  
Regulation 1935/2004/EC (contact with food)

#### Harmonized European standards

EN 12100-1 and 2: 2004 - EN 60204-1: 2006  
EN 60335-2-64: 2004 Commercial electric kitchen machines

CE (European standards),  
NSF (USA), UL (USA) and cUL (Canada), KC (Korea)

#### Electrical safety

- On/Off interlock switch is waterproof
- All mechanical parts are ground (earth) connected
- All equipment is 100% tested at the end of assembly (special electrical testing bay)

#### Thermal safety

Motor protected by internal thermal detector.

#### Acoustic safety

The asynchronous motor with direct driving is particularly silent.

#### Hygiene

All removable parts can be put in a dishwasher or easily cleaned with hot soapy water (NSF approved).

**PRODUCT: 2-YEAR WARRANTY | MOTOR: 5-YEAR WARRANTY**

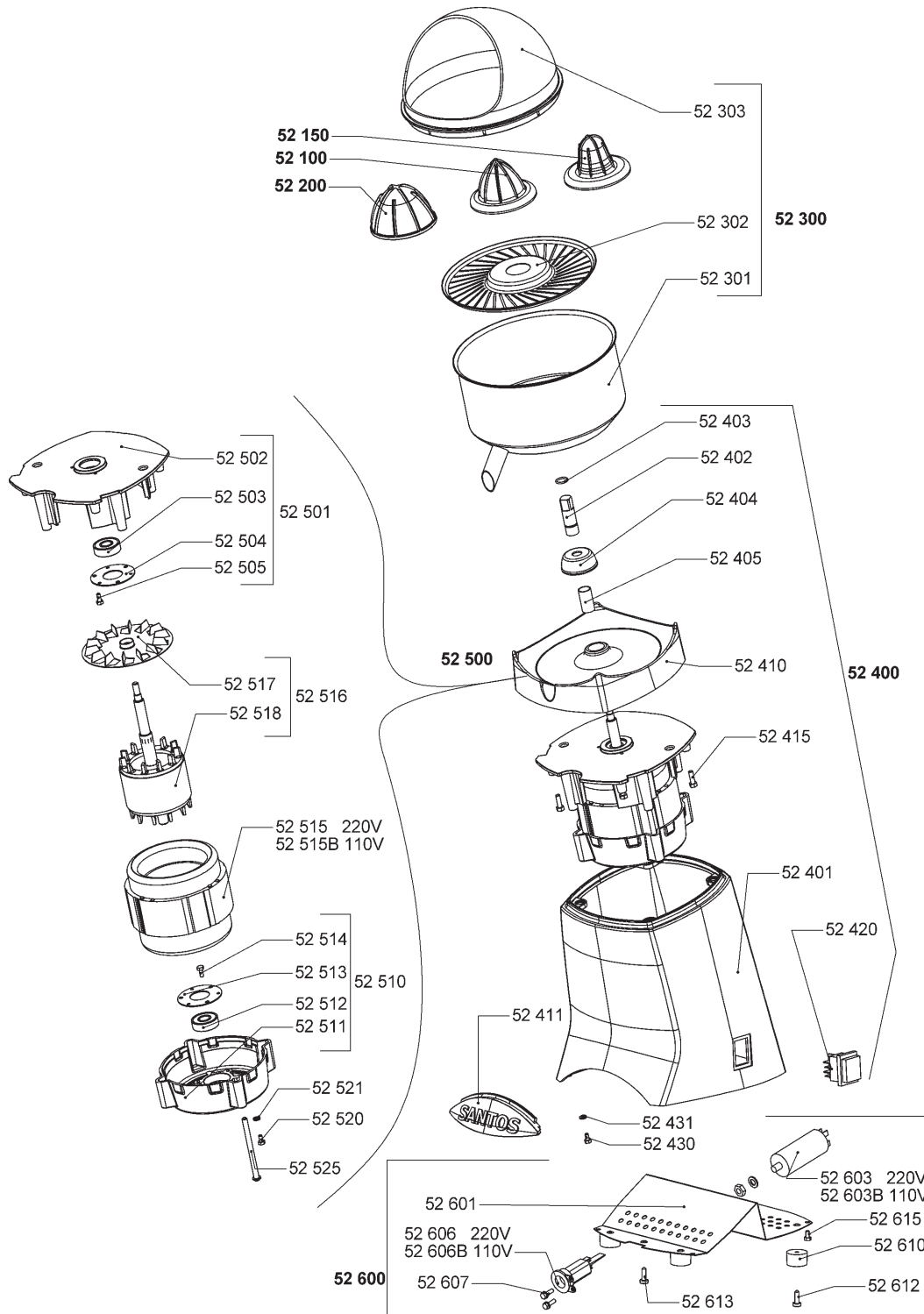

**SANTOS**

140-150 Avenue Roger Salengro BP 80 067 – 69511 Vaulx-en-velin Cedex (Lyon) – FRANCE  
 Tel. +33 4 72 37 35 29 – Fax. +33 4 78 26 58 21 – Website: www.santos.fr – Email: santos@santos.fr

Follow us on #SantosAddict social networks