



PROJECT _____

ITEM NO: _____

QUANTITY: _____

Work Tables With Built-In Sink

Operation: Right Sink



NSF Certified

FEATURES & CONSTRUCTION:

- Top is fabricated with 1-1/2" rounded front edge, flat edge on both ends and 45° slanted backsplash.
- Table front edge formed with hemmed edges to provide extra rigidity and safe to touched finished.
- Sink bowl to have coved corner with 3/4" radius.
- Reinforced table top with sound deadened hatch channels.
- Adjustable undershelf secure to leg aluminum die cast clamp.
- All exposed welded areas smooth polished to brush finish sanitary #4.
- Welded leg socket for removable table legs.
- All tables shipped K.D. and easily assembled.



SMTPS-2448R

MATERIAL:

- Top: 16 Ga. Stainless Steel - 304
- Sink Bowl: 16 Ga. Stainless Steel - 304
- Shelf: 18 Ga. Stainless Steel - 400 series
- Leg: 1 5/8" Stainless Steel Tubing, Stainless Steel Leg Socket, 1" Adjustable Stainless Steel Bullet Feet.



SMTPS-3072R

MODEL#	TABLE SIZE			SINK BOWL SIZE		
	L	W	H	A	B	C
SMTPS-2448R	48"	24"	35 1/2"	16"	16"	11"
SMTPS-2460R	60"					
SMTPS-2472R	72"					
SMTPS-3048R	48"	30"	35 1/2"	16"	20"	11"
SMTPS-3060R	60"					
SMTPS-3072R	72"					

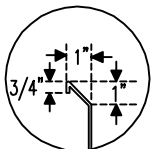

45° Slanted Backplash

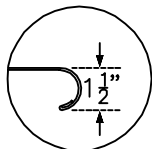

Rolled Rim Edge Front And Rear Reinforced with Hemmed Edge

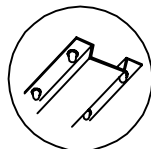

Hatch Channel Supported



Aluminum Die Cast Clamp For Adjustable Under Shelf



1" Adjustable Bullet Feet



3 1/2" Drain Basket Included



SAPPHIRE MANUFACTURING
 Tel: 718-543-2111
 Fax: 718-543-2121

Rev. 11/16

info@sapphiremanufacturing.com
 WWW.SAPPHIREMANUFACTURING.COM



PROJECT

ITEM NO: _____

QUANTITY: _____

Work Tables With Built-In Sink

Operation: Right Sink



NSF Certified

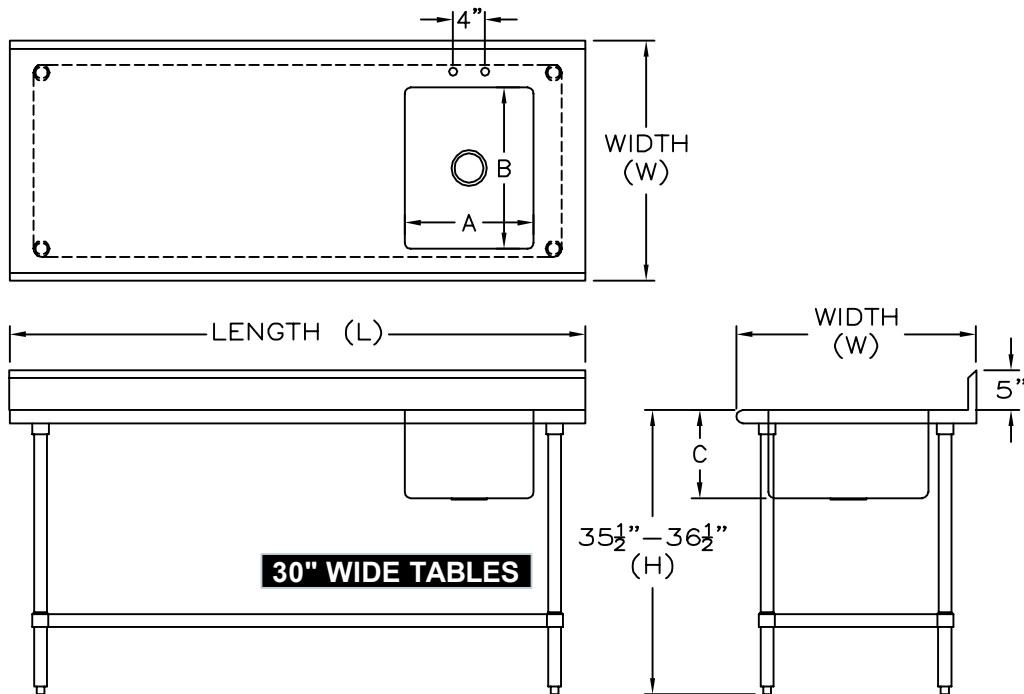
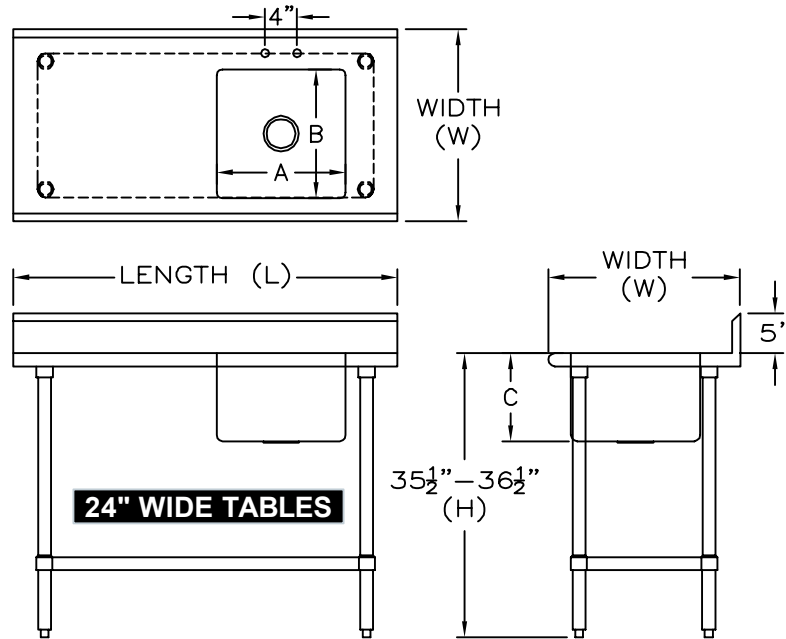

Specifications subject to change without notice.

All dimensions are typical (Tolerance 1/2").



SAPPHIRE MANUFACTURING
Tel: 718-543-2111
Fax: 718-543-2121

info@sapphiremanufacturing.com
WWW.SAPPHIREMANUFACTURING.COM

Rev. 11/16